

MANUAL BEVELLING AND DEBURRING SYSTEM B22 ZERO



Ord.no. 27 220

Operation manual for the device

SUBJECT TO CHANGE

Contents:

General information	3
Machine description B22 ZERO	3
Identification data	3
Reference standards	4
Tests	4
Warranties	4
Safety regulations	5
Technical specifications	6
Accessories	7
Machine equipment	7
Control elements B22 ZERO	7
Use	8
Bevel angle adjustment	8
Setting the bevel height - reduction	8
Bevelling	10
Machining 0° - FACING	11
Pipe bevelling	12
Additional handle	14
Replacement of indexable inserts	16
Replacement of milling head – tools	17
Maintenance and operation	18
Spare parts	18
List of spare parts	19 - 25



Read the operation manual carefully prior to use

1. General information

Thank you for purchasing one of our machines, and we hope that you will be fully satisfied.

This guide provides instructions for the installation, adjustment, operation and maintenance of the machine B22 ZERO in compliance with valid safety standards.

The information and data contained in this document subject to changes due to further improvement of machinery. To eliminate any doubts, when differences are detected, please contact N.KO Machines.

Never perform any operation on the machine before you read the instructions in the manual and understand them. Major part of accidents that happen in the workplace are due to the fact that the guidelines and recommendations contained in the manual are not complied with.

The graphic symbols used in the manual are intended to emphasize the important information regarding the safety and operation of the machine.



Attention :

Information important for the personal safety of the operating staff.



Important:

Instruction that needs to be observed to ensure the proper function of the machine.

2. Machine description B22 ZERO

Machine B22 ZERO is designed solely for the activities below:

B22 ZERO is designed solely for bevelling, fetch fettling, and the removal of material layer on the workpiece edge occurred during the sheet metal removal by soldering – i.e. FACING. To be performed solely on metal materials in the workshop in the production hall.

This includes manual and manually managed machine. The main feature of the machine is the ability to machine flat and shaped workpieces, profiles, and tubes.

The machining angle can be changed without the necessity to use any tools.

Use the machine in the environment protected from rain, snow, and other adverse weather conditions.

3. Identification data

The identification data of machine B22 ZERO are listed on the label placed on the motor unit.

3.1. Reference standards (CE Declaration of Conformity)

EC Declaration of Conformity

1. Name and surname of the declaration issuer: N.KO spol s.r.o.
Address of the declaration issuer: Tábořská 398/22
CRN: 2616109
2. Subject matter of the declaration:
Name: HAND HELD BEVELLING MACHINE
Type: B22 ZERO
Manufacturer: N.KO, spol. s r.o.
3. Intended use: Edge bevelling of sheets as preparation for welding .
4. The above-stated subject matter of the declaration complies with requirements of the following documents:

Directive 2006/42/EG: Machinery Safety – Basic Requirements

Directive 2014/30/EU: Electromagnetic Compatibility

Directive 2011/65/EU: Absence of hazardous substances

EN ISO 12100: Safety of machinery - Basic concepts, general principles for design – Risk Assessment and Risk Reduction

EN ISO 13857: Safety of machinery – Safety distances to prevent hazard zones being reached by upper and lower limbs

EN 953: Safety of machinery – Guards – General requirements for the design and construction of fixed and movable guards

EN 60204-1: Safety of machinery – Electrical equipment of machines

ČSN EN 60745-1 ed. 3: 2009

except art.21.18 Hand held electromechanic tool – safety – part 1: general requirements

ČSN EN 60745-2-17 ed. 2: 2010

Hand held electromechanic tool – safety – part 2-17.

Specific requirements for upper and flattening milling machines

5. Data on accredited / notified person:
Date and place of issue: 1. February 2017, Mladá Boleslav
Name and position of the authorized person: Milan Richtr – managing director

Signature of the authorized person:



3.2 Device construction as regards safe operation

Device B22 ZERO fulfils the below statements:

- The tools are constructed and covered to ensure sufficient protection from random contact with live parts.
- The tools in case of common load do not reach excessive temperatures.
- The tool cover provides sufficient level of protection from moisture in compliance with the tools' classification.
- The tools are constructed in such way the fire hazard, mechanical damage with negative effects on safety or injury from electrical current was eliminated at the highest achievable level due to abnormal activity.
- The handles are shaped and placed in such way to minimize the hazard of accidental hand contact of the user with rotary parts.
- The tools have sufficient mechanical solidity and it is constructed to be resistant to rough treatment which can be expected during common use.
- The parts used for the provision of required level of protection from moisture cannot be removed without the tool.
- The tools construction does not include asbestos.
- Parts difficult to remove which provide required level of protection from electrical current injury, from moisture, and from contact with moving parts are reliably attached and resistant to mechanical load which occurs during common use.
- The handles, buttons, grips, levers, and similar parts are reliably attached to prevent releasing during common use, if such release could cause danger.
- Parts conducting current and other parts where corrosion could cause hazards, are resistant to corrosion.
- The shafts of the control buttons, grips, levers, and similar parts are not live parts.
- The conductors are protected to prevent the contact with burrs, cooling ribs, etc. which could cause damage to the insulation of conductors.
- The openings in the metal with passing insulated conductors are fitted with bushing, they are smooth and with well rounded edges.
- The conductors are effectively protected from contact with moving parts.
- The internal lines and electrical connections between various parts of the tools are sufficiently protected or covered.
- For indoor lines there are no aluminium conductors. Winding is not considered to be internal line.
- The parts comply with the safety requirements defined in the respective standards IEC within the scope efficient for the application of the standards.
- If the parts include indicated work characteristics, the conditions for the use of the parts in the tools must comply with this marking, unless special exception is defined.
- The tools do not include:
 - switches or automatic control devices in the moving supplies, RCD are permitted;
 - the devices which in case of the tools defect activate the safety device in fixed electrical line;
 - thermal fuses which can be again set to the original state by soldering.
- The external parts from non-metal material, part from insulating material which maintain live parts including the electrical connections in the defined position, and parts from thermoplastic material providing additional insulation or reinforced insulation which in case of damage could cause the tools noncompliant with the requirements of the standard, must be sufficiently resistant to heat.
- The tools do not emit hazardous radiation and it does not represent toxic or similar hazard.



4. Tests

The machine for edges bevelling is tested in our test room.

During that test, the correct function of bevelling sheets and profiles by different types and sizes, are tested.

5. Warranties

The B22 ZERO is provided by the seller with a guarantee that the article shall not feature any material and production defects for a period of 12 months following the delivery date.

The machine is provided with a 12-months' guarantee from the delivery date for the faultless function of the article and the materials used.

The seller undertakes to make sure that any potential warranty defects are removed free of charge and without undue delay so that the buyer is able to use the article the way they desire. Should the buyer claim liability for warranty-unrelated defects, it shall reimburse the seller for any expenses associated with that.

The manufacturer considers the guarantee invalid if:

- the machine is improperly used.
- used in conflict with national or international standards
- improper installation
- Defective supply of compressed air or its adverse quality
- severe shortcomings in maintenance
- unauthorised modifications or interventions
- other than the original or unapproved parts and accessories by the manufacturer are used for that model;
- full or partial failure to follow the instructions in this manual
- extraordinary events, natural disasters or the like.

6. Safety regulations

Attention :

In order to prevent the injury observe the below instructions

Inspect the machine for mechanical and other damage prior to use. **Stroj uvádějte do provozu jen v případě, že není nijak poškozen přívodní napájecí kabel.**

Check the supply cord regularly. In case of damage have it replaced in an authorised service shop authorised to perform the such repairs. Contact your supplier.

Personal protection from injury

During the work use safety goggles, solid work footwear, hearing protection, suitable head cover, e.g. safety helmet.

- Connect the machine in electrical network solely if the machine is in off position.
- Prior to each use, check the device and supply cord for damage. Do not use the machine in case of any damage.
- Do not use the machine in humid environment and protect from high moisture.
- Ensure good lighting at the workplace to prevent the risk of potential injury or eyesight damage.
- Caution, the tool (milling machine) is sharp with the risk of injury. During the replacement use safety gloves, **never touch the tool which moves.**
- The machined material must always be fastened and horizontal. Optimum workpiece height is 900 mm above ground.
- Pay attention to the supply cable during work. It should be loosely placed on the ground outside the worked material and other sharp objects.
- After work, disconnect equipment from the electricity supply.
- Do not overload the machine motor. The machine operates better if not overloaded.
- During work, hold the device by both hands.
- Attention is drawn to the injury hazard with hot metal shavings.



Attention :

During work, hold the device by both hands. The switch must be within the reach of left hand of the machine operation employee, see figure 6.0.1.

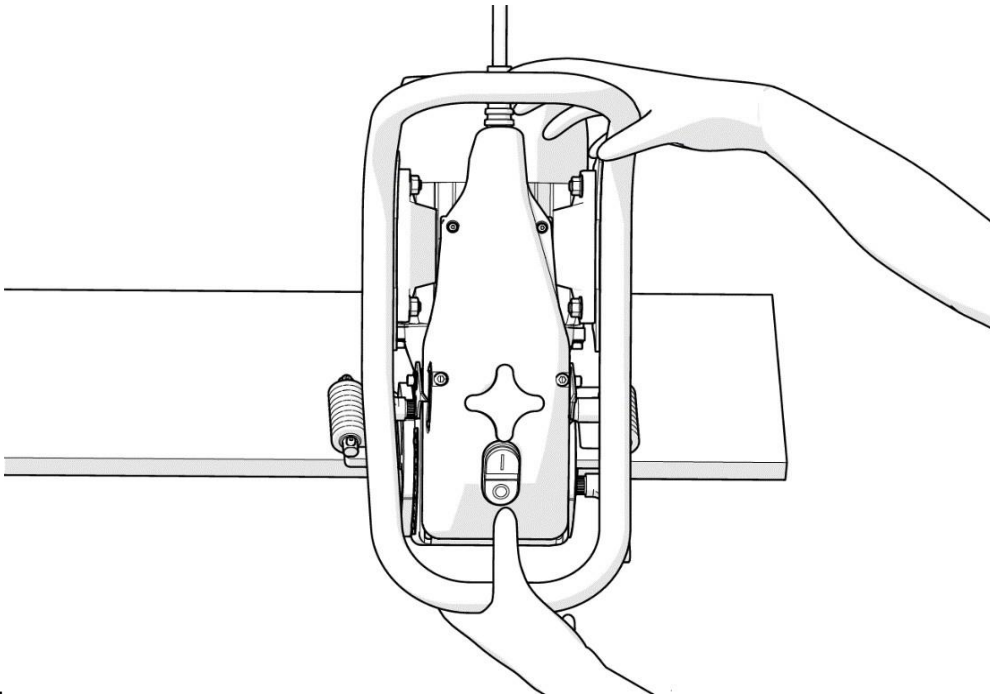

Fig. 6.0.1



Important:

In case of damage have the machine repaired in an authorised service shop authorised to perform the repairs. For more information on, contact your supplier.

7. Technical specifications

Bevel angle	Infinitely adjustable within the range from 0° to 60°
Bevel width	0 to 20 mm < 400N/mm ² - 0 to 16 mm > 400N/mm ²
Machining width for FACING	22mm
Motor	Electric 400V 1,1 kW / 50Hz, 480V 1,3kW / 60Hz, 3x 220V 1,1kW / 60Hz
Motor power	1,1kW (400V) / 1,3kW (480V)
Revolutions	2850 rpm (50Hz) / 3420 rpm (60Hz)
Weight	19.5 kg
Number of indexable inserts	10 pcs

8. Accessories

Milling head STANDARD (incl. inserts, screws)	29 201
Milling head PREMIUM for stainless steel (incl. inserts, screws)	29 202
Cutting plates STANDARD	29 203
Cutting plates PREMIUM for stainless steel and head 29 202	29 205
Adapter for tube and pipe bevelling	29 204
Additional handle	29 206

9. Machine equipment

Unpack the machine from the cardboard and check if the machine is ok and free from damage. If necessary contact the seller.

Machine B22 ZERO is supplied with required tools for the operation without the connection socket. It is necessary to assemble the respective socket according to the standards and regulations of the respective country.

10. Control elements B22 ZERO

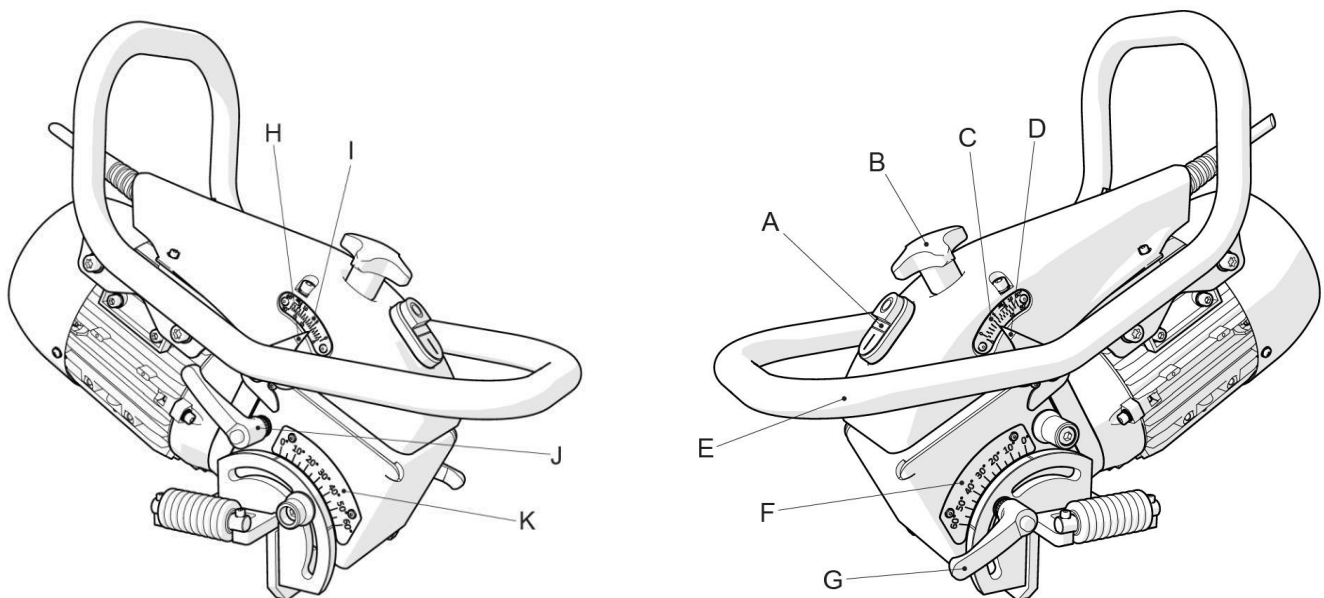

- | | |
|--|---|
| A. Main switch | B. Reduction size control rosette |
| C. Reduction size scale for 60° and 50° | D. Reduction size indicator for 60° and 50° |
| E. Handrail | F. Left scale for setting the bevel angle |
| G. Bevel angle arresting | H. Reduction size indicator for 45° and 30° |
| I. Reduction size scale for 45° and 30° | J. Reduction size setting arresting |
| K. Right scale for setting the bevel angle | |

11. Use

 Attention :

During the adjustment operation, wear gloves and other personal protective equipment. The operations must be carried out on the machine at rest and after disconnecting from the power supply.

11.1. Bevel angle adjustment

- Disconnect the machine from electricity supply.
- Release the setting arresting lever (fig.10.0.1 position G)
- By gradual tilting of rulers set the required machining angle. You can reduce the value on the angle setting scale (fig.10.0.1 position F and K).
- After setting, re-fasten the arresting lever (fig.10.0.1 position G).

11.2. Bevel height adjustment

- Disconnect the machine from electricity supply.
- Release the setting arresting lever (fig.10.0.1 position J)
- Turn the rosette (fig.10.0.1 position B) for setting the reduction size. Actual setting is displayed on the scales on both electrical wiring sides (fig.10.0.1 position I and C) by means of composite indicators (fig.10.0.1 position H and D) The scale is used for orientation reading of the bevel height value (dimension A fig.11.2.2) for angles 30°, 45° on one and 50° and 60° on the other bonnet side (fig.11.2.1). Setting for other angles must be estimated.
- After setting, re-fasten the arresting lever (fig.10.0.1 position J).

11.2.1

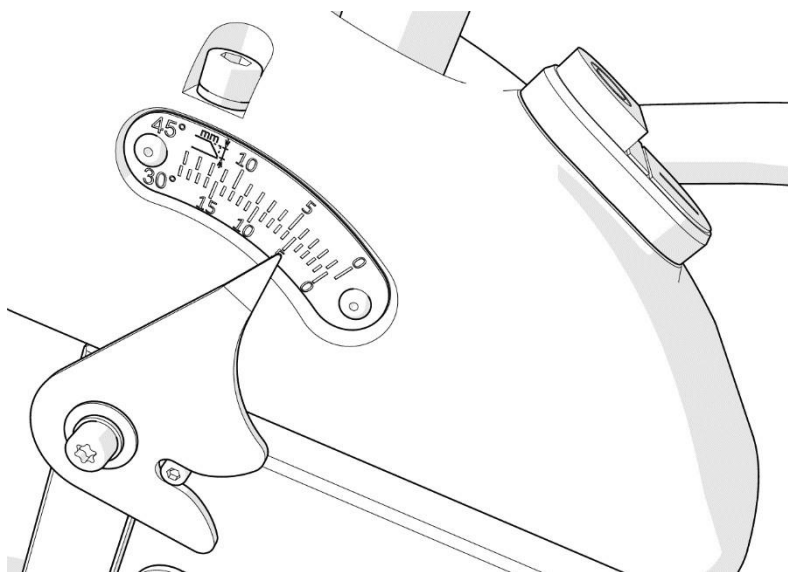

Important:

Maximum bevel width for machine B22 ZERO - 20mm (dimension P fig.11.2.2).

It is necessary to be aware that the scales (fig. 10.0.1 pos.I and C and fig. 11.2.1) are for setting the bevel height (dimension A fig.11.2.2)

Maximum possible reduction can be achieved solely in more reductions. It depends on the bevel angle and material solidity. We recommend performing the test.

Start with lower reduction and gradually increase the value until the work with the machine is comfortable and the plates can achieve gradually reduction without increased vibrations. In order to achieve the maximum machining regardless the bevel we recommend proceeding according to table (fig. 11.2.2).

We recommend administering the work log for recording the measured value and the machining procedure.

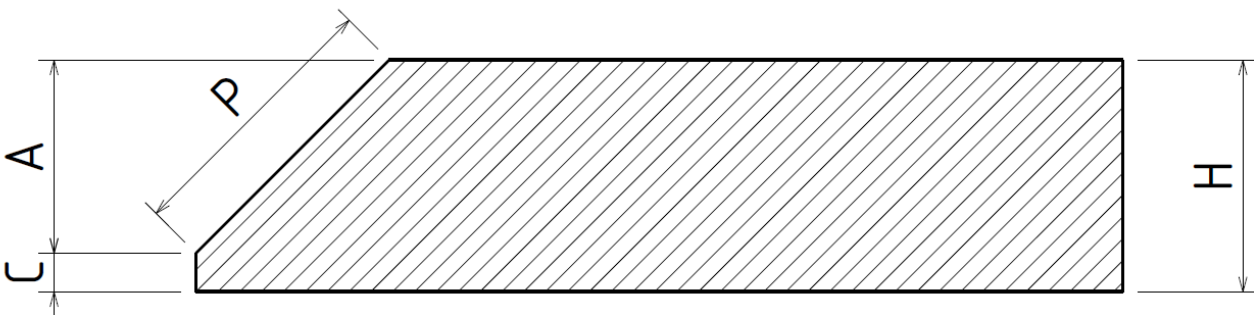

Chip no.	max P	Bevel height A	Number of recommended reductions
30°	20mm	17mm	3 reductions
45°	20mm	14mm	4 reductions
50°	20mm	13mm	4 reductions
60°	20mm	10mm	5 reductions

Important:

The machine was constructed for the preparation of welded surfaces. Machining accuracy is within limit +/-1mm. The condition for reaching the satisfactory results is a perfect preparation of the material edges. Unfortunately the material is often burned or cut. The inaccuracy shall be reflected on the resulting accuracy and quality of machining.

Important:

If it is difficult to machine the bevel within the recommended number of steps, we recommend dividing the process to more chips. The reason can be the wear of the cutting inserts or worse machining properties of material.

11. 3. Beveling

Important:

The device can be used solely if it is fitted with the original indexable inserts supplied by our supplier, i.e. the device manufacturer. It includes four-sided indexable inserts (order no. 29 203). The device can be fitted with 10 pieces of indexable inserts. We do not recommend using other than original inserts.

- Connect the machine to electricity supply.
- Attach the adjusted machine on the material side in such way the horizontal and vertical guiding bar is in contact with material.
- Grip the machine in the handle area and start gradually shifting from the right to the left (fig. 11.3.1). Be aware that at the start of machining when the vertical and horizontal bars are not in contact with material with the whole length, the machine is more susceptible to vibrations.
and it is less stable. Proceed with care. The same effect occurs at the end of the material during the machine extraction from the reduction.
- Slowly move the machine to the material until you feel the milling machine is in reduction. CAUTION!!! The rebound is possible at this moment, be careful.
- Shift the machine alongside material constantly, using only such speed the milling machine was able to remove material in the set chip profile. Otherwise, the milling machine will be pushed out from the material and the bevel will be unequal.

Fig.11.3.1

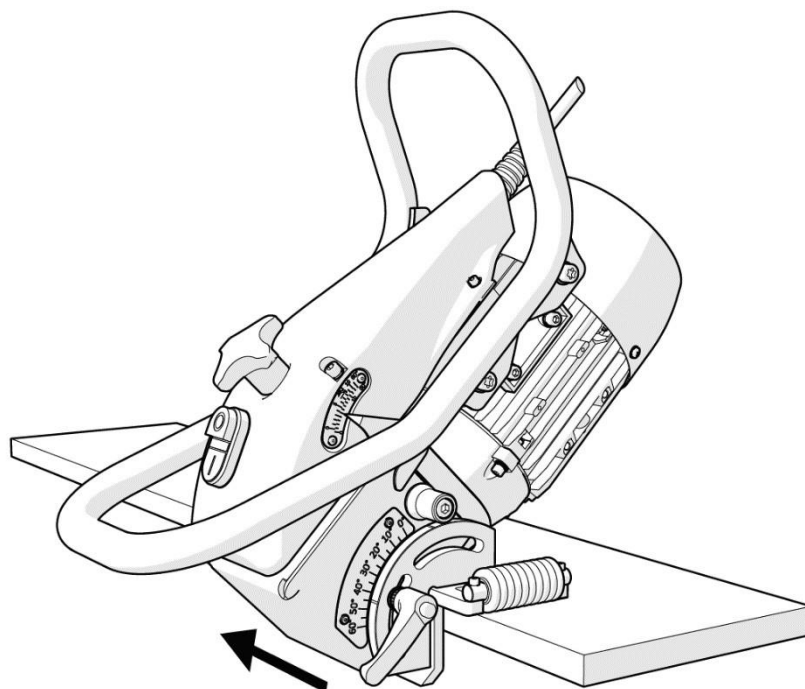

11. 4. Machining the material edge under angle 0° - FACING

- Set the working angle 0° on the machine
- Fit the milling machine outside the working zone in order to prevent contact with material at the moment of loading the machine on sheet metal. Proceed according the chapters 11.2
- Connect the machine to electricity supply.
- Fit the machine on material at any part of its length. Horizontal and vertical guiding bar must be in contact with material at its whole length.
- Switch on the machine and slowly turn the bevel size setting (fig.10.0.1 position B) with the control rosette to bring the milling machine closer to the material. At the moment you hear the contact of the milling machine with material occurred, stop turning the rosette (fig.10.0.1 position B) and secure the position with the arresting lever (fig.10.0.1 position J).
- Remove the machine from the material. Now release the arresting lever (fig.10.0.1 position J) and set the required depth of machining with the rosette (fig.10.0.1 position B). It commonly set to 1-2mm.
The setting size must be estimated. There is no scale. Set the machining size when the machine can be safely shifted alongside the material.
- Attach the machine on the material side in such way the horizontal and vertical guiding bar is in contact with material (fig.11.4.1.).
- Grip the machine in the handle area and start gradually shifting from the right to the left. Be aware that at the start of machining when the vertical and horizontal bars are not in contact with material with the whole length, the machine is more susceptible to vibrations and generally less stable. Proceed with care. The same effect occurs at the end of the material during the machine extraction from the reduction (fig.11.4.1.).
- Slowly move the machine to the material until you feel the milling machine is in reduction. CAUTION!!! The rebound is possible at this moment, be careful.
- Shift the machine alongside material constantly; using only such speed the milling machine was able to remove material in the set machining depth. Otherwise, the milling machine will be pushed out from the material and the machining shall be unequal.

Fig. 11.4.1

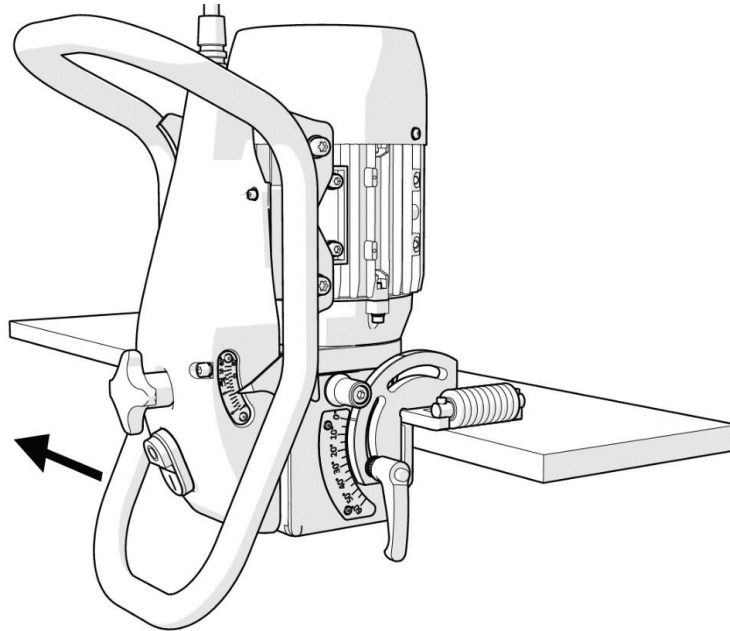

Attention :

During work, wear gloves and other personal protective equipment.

The maintenance operations must be carried out on the machine at rest and after disconnecting from electricity supply.



Important:

The shift during machining is always from right to the left.



Attention :

The device operators must hold the device with both hands. When the milling machine starts machining, the rebound is possible! Hold the device solidly and set only such bevel size to keep the machine under control. The switch must be within the reach of left hand of the machine operation employee, see figure 6.0.1.

11.5 Tube and pipe bevelling

Machine B22 is constructed for machining the tubes and pipes from minimum diameter Ø150mm. It is provided by a special tube preparation which must be assembled on the machine.

Order no. 29 204. Assemble the preparation on the machine instead of horizontal ruler, as follows:

- Disconnect the machine from electricity supply.
- Unscrew 4 socket head screws (fig.11.5.1 position B) and disassemble the basic horizontal ruler (fig.11.5.1 position A)
- Instead assemble the device on the tubes (fig.11.5.1 position C). Use original socket head screws.

Fig. 11.5.1

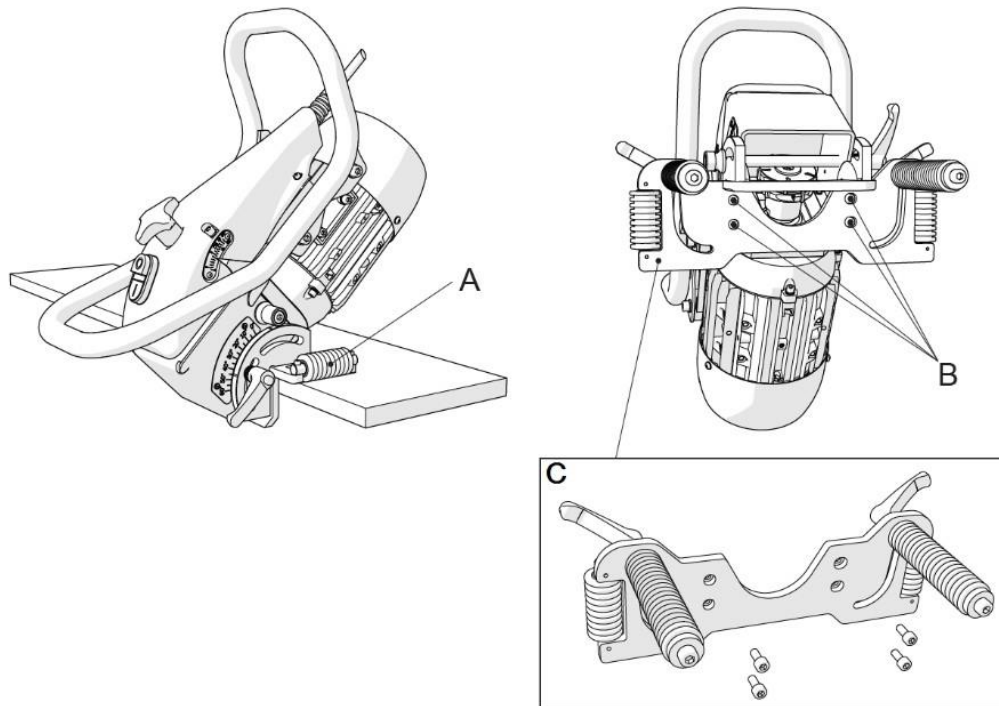

The preparation adjustment procedure on the tubes and beveling the tubes:

- Release both arresting levers of the preparation rolls position adjustment on the tubes (fig.11.5.2 position N) and set the suitable position according to the diameter of worked tube in such way the machine touches the tube periphery with the rulers and both rolls at the same time.
- Setting the bevel size and perform the machining angle according to former chapters 11.1 and 11.2
- Connect the machine to the electricity supply and switch on the main switch (fig.10.1.1 position A)
- Fit the machine on the tube in position according to the figure (fig.11.5.2 and 11.5.3) and apply gradual pressure to press the material in full profile of the set machining. Pay attention to the rebound!
- Start shifting the machine around the tube clockwise so both guiding rolls and the centres of both rulers are in permanent contact with the tube. Otherwise, the bevel shall not be balanced.

Fig. 11.5.2

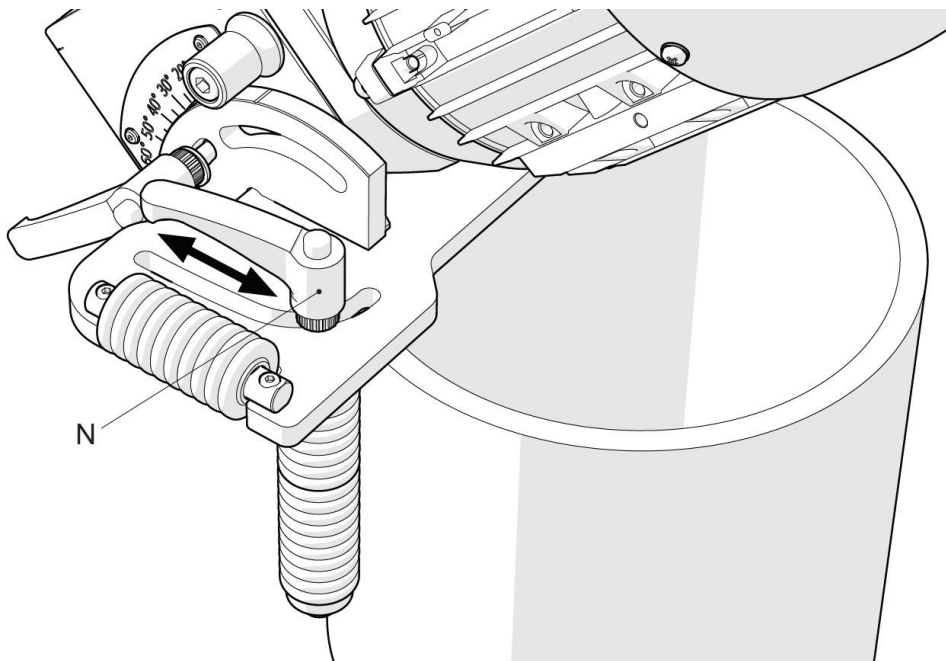
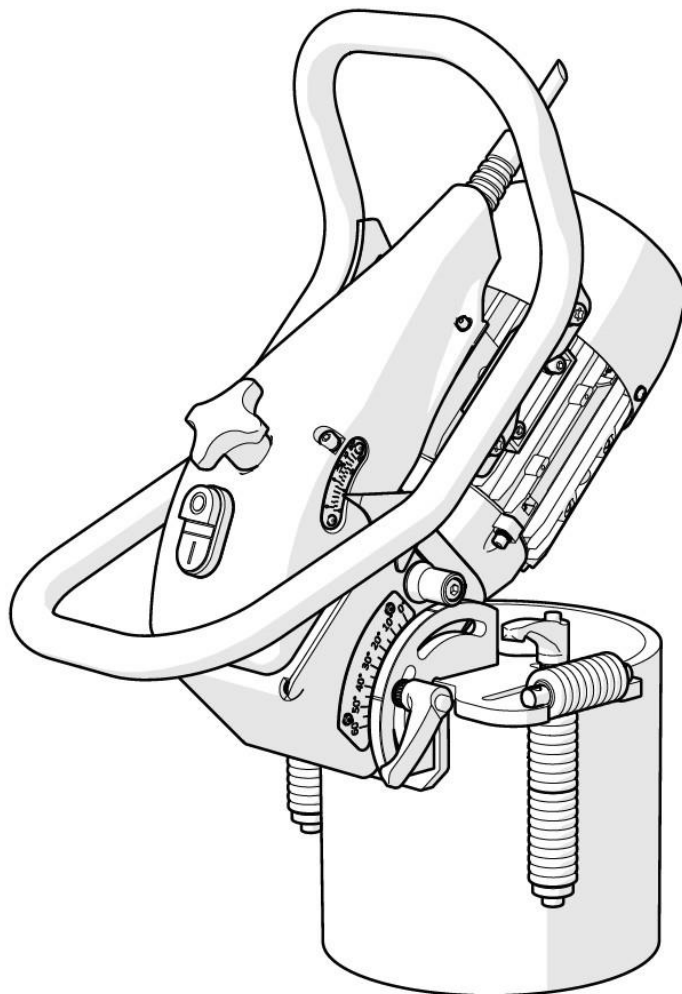

Fig. 11.5.3





Attention :

During the adjustment operation, wear gloves and other personal protective equipment. The operations must be carried out on the machine at rest and after disconnecting from the power supply.

11.6 Use the additional handle

It is possible to buy additional handle to the machine to improve the ergonomics of the machine and achieve higher production rate. The work with the machine is also more comfortable.

The handle is always assembled under the machine safety frame screws (fig.11.6.1 position A) and it can be assembled in four positions to enable simple work with the machine in every position, see fig. 11.6.1.

Fig. 11.6.1

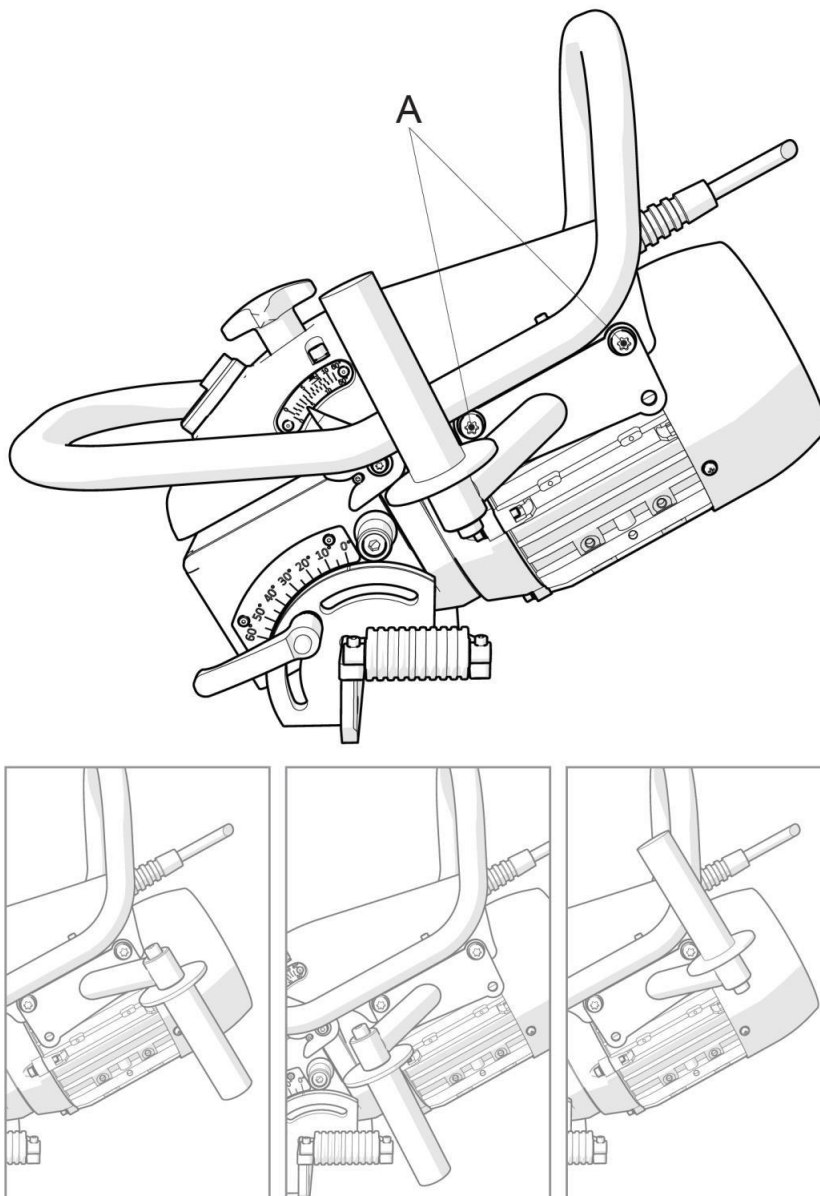

12. Machine maintenance:

12.1 Replacement of indexable inserts and milling machine

Important:

Work solely with sharp and not damaged indexable inserts. It prevents the machine damage. If the cutting inserts are worn or damaged, they must be replaced.

Important:

The device can be used solely if it is fitted with the original indexable inserts supplied by our supplier, i.e. the device manufacturer. It includes four-sided indexable inserts (order no. 29 203). The device can be fitted with 10 pieces of indexable inserts. We do not recommend using other than original inserts.

Replacement of indexable inserts:

- Disconnect the machine from electricity supply.
- Set the machine into the vertical position on the motor fan cover.
- Completely unscrew the arresting lever for the reduction size setting (fig. 12.1.1 position J) and extract the screw completely from the machine.
- Dismantle the whole set of the machine bonnet.
- Attach the wrench (fig. 12.1.2 position A) release individual plates (fig. 12.1.2 position B) and replace it with new ones.
- Reset the machine in the opposite

process Fig. 12.1.1

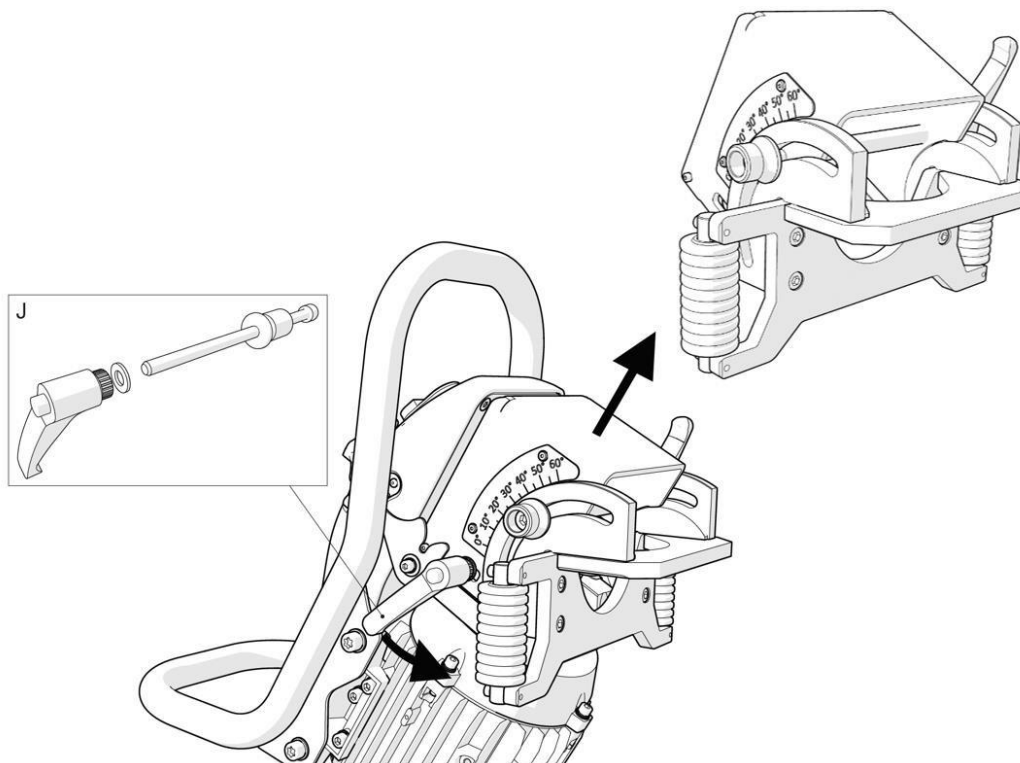
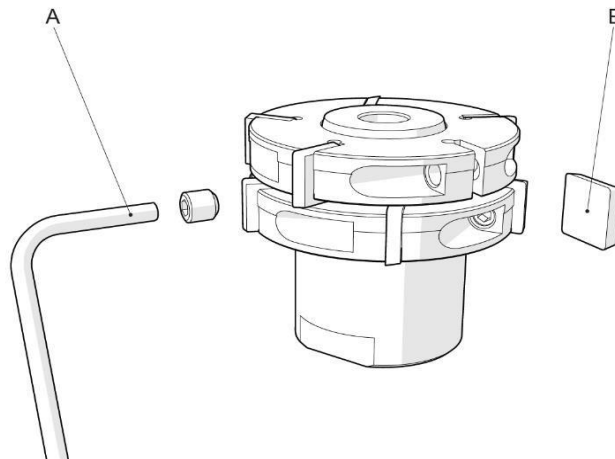

Fig. 12.1.2



Dismantling the milling head (tool):

- Disconnect the machine from electricity supply.
- Set the machine into the vertical position on the motor fan cover.
- Completely unscrew the arresting lever for the reduction size setting (fig. 12.1.1 position J) and extract the screw completely from the machine.
- Dismantle the whole set of the machine bonnet (fig. 12.1.1)
- Attach the side wrench to secure the milling machine against turning. (Fig. 12.1.3 position M)
- Attach the socket head screw and release and completely unscrew the attachment screw (fig. 12.1.3 position L)
- Remove the milling machine from the shaft with hand or suitable

removal preparation. Fig. 12.1.3

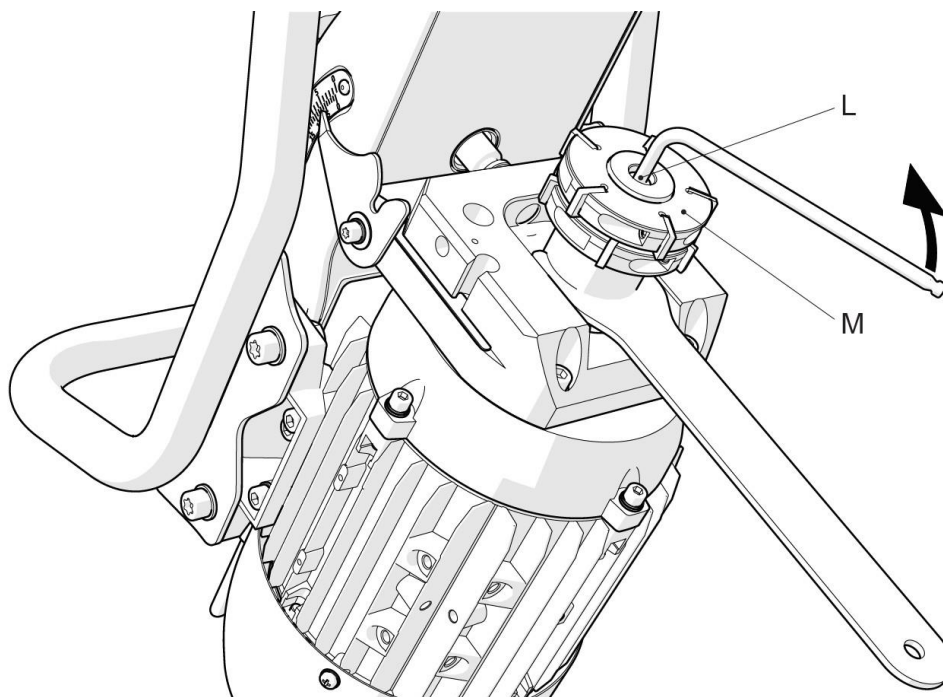

12.2 Maintenance and cleaning

Machine B22 ZERO is a very simple construction and it does not require complicated maintenance. Keep the machine, mechanical moving parts, threads, and tools clean.

Work solely with sharp and not damaged and complete tools.

 Important:

The moving parts, threads, and rolls must be gradually cleaned using compressed, and must be preserved (greased).

 Attention :

When using compressed air for cleaning, wear safety goggles and never use a pressure exceeding 2 bar.

13. Spare parts and electric connections

Orders of spare parts shall contain the following information:

- machine type;
- serial number;
- Description of required part and its number
- quantity.

Electric wiring diagram:

400V or 3x 220V SCHEMA ZAPOJENI

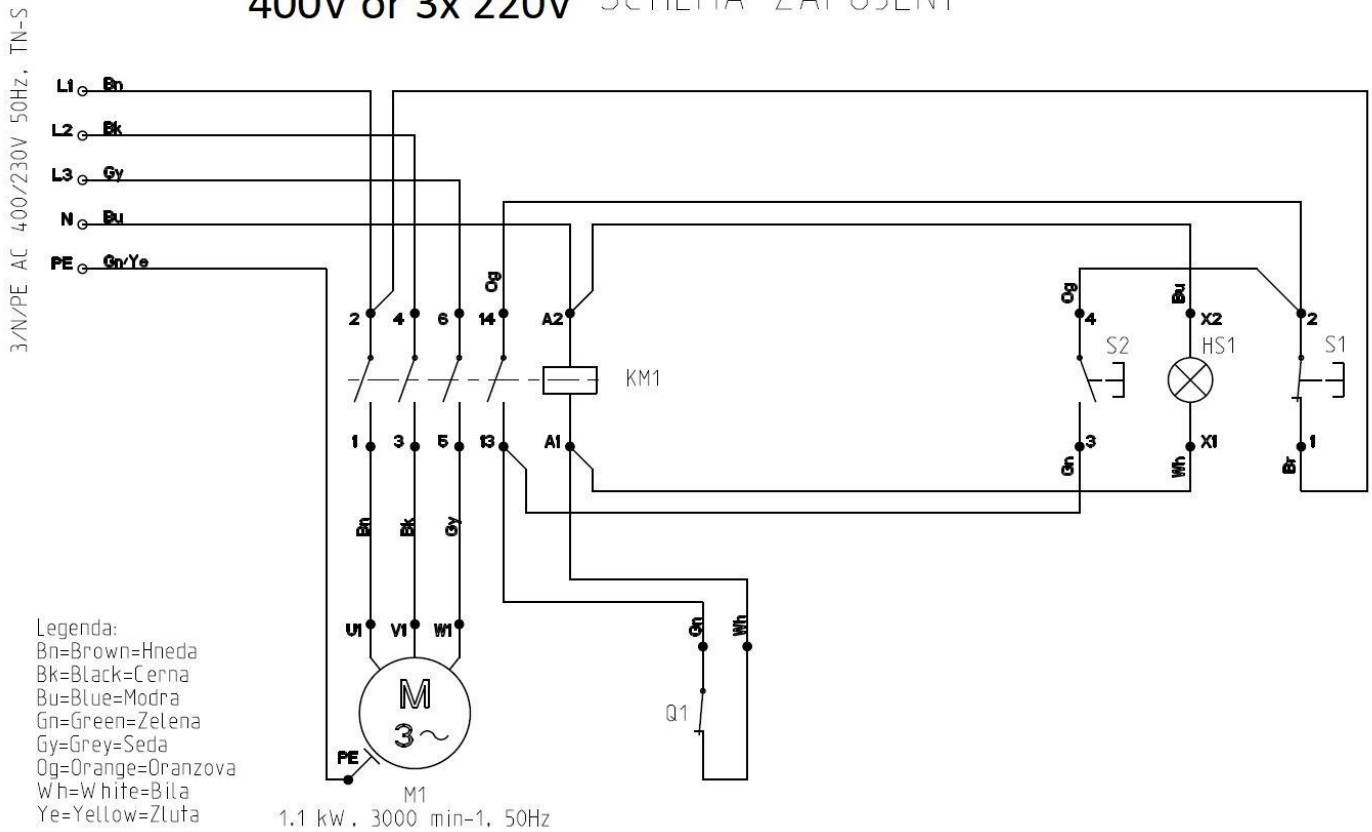

SCHEMA ZAPOJENI 480V

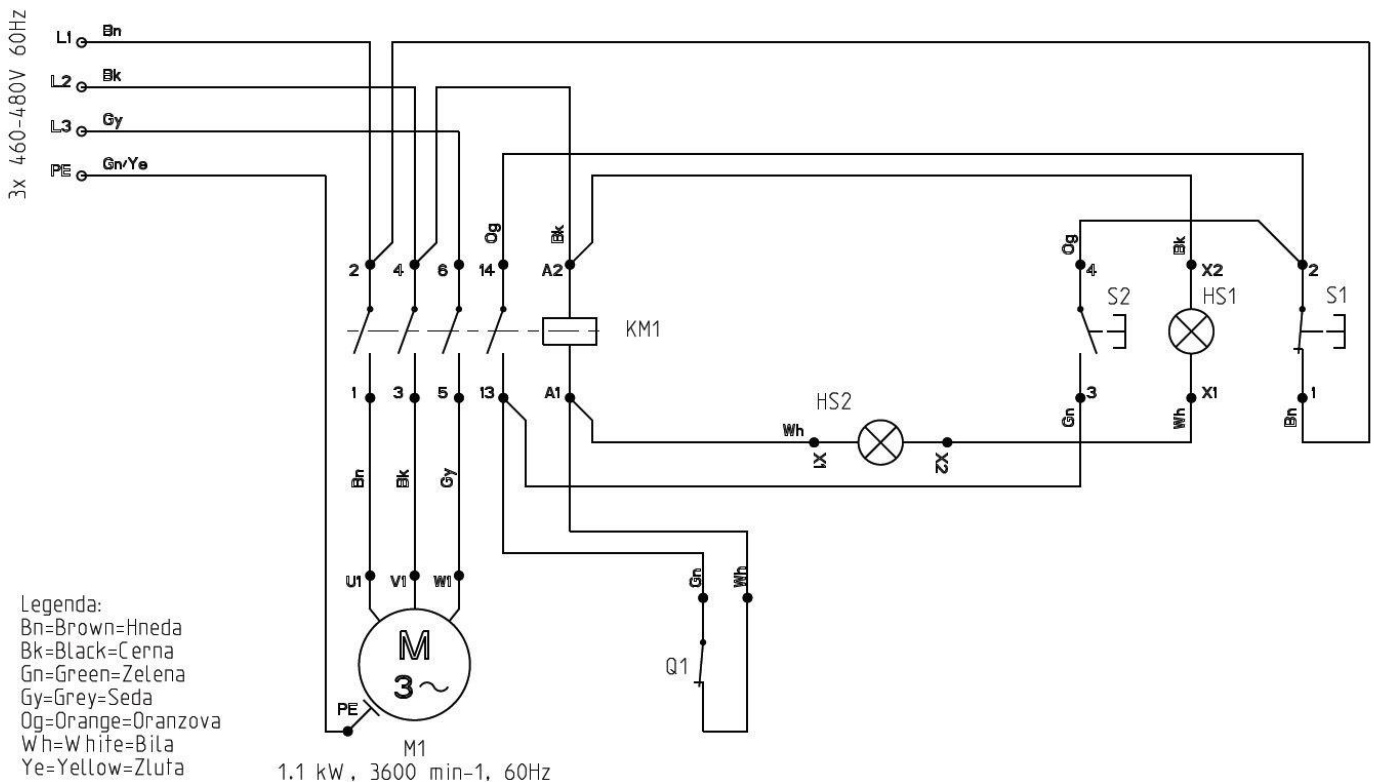

13.1 List of spare parts

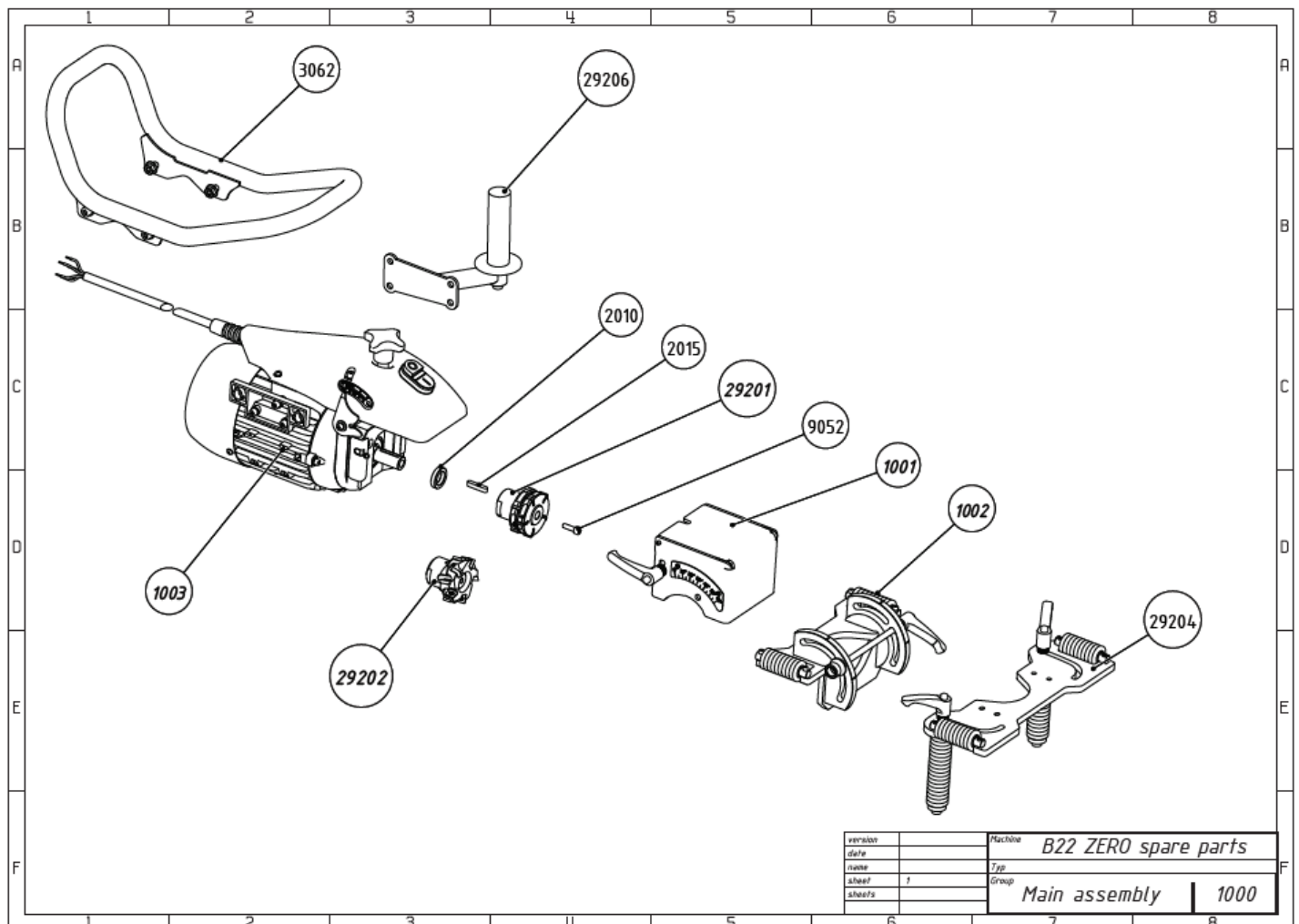

version		Machina	B22 ZERO spare parts
date		Typ	
name		Group	Main assembly
sheet	1		1000
sheets			

B22 ZERO SPARE PARTS

drawing no. **1000** Main assembly

Number	Fig	Part name	Note
29200.1001	1001	head assembly	see assembly list 1001 Head assembly
29200.1002	1002	set of rulers	see assembly list 1002 Set of rulers
29200.1003	1003	engine assembly	see assembly list 1003 Engine assembly
29201	29201	milling head standard	see assembly list 29201 Milling head standard
29202	29202	milling head premium	see assembly list 29202 Milling head premium
29204	29204	adapter for tubes	
29206	29206	additional handle	
29200.2010	2010	washer	
29200.2015	2015	key	
29200.3062	3062	main handle	
29200.9052	9052	screw	

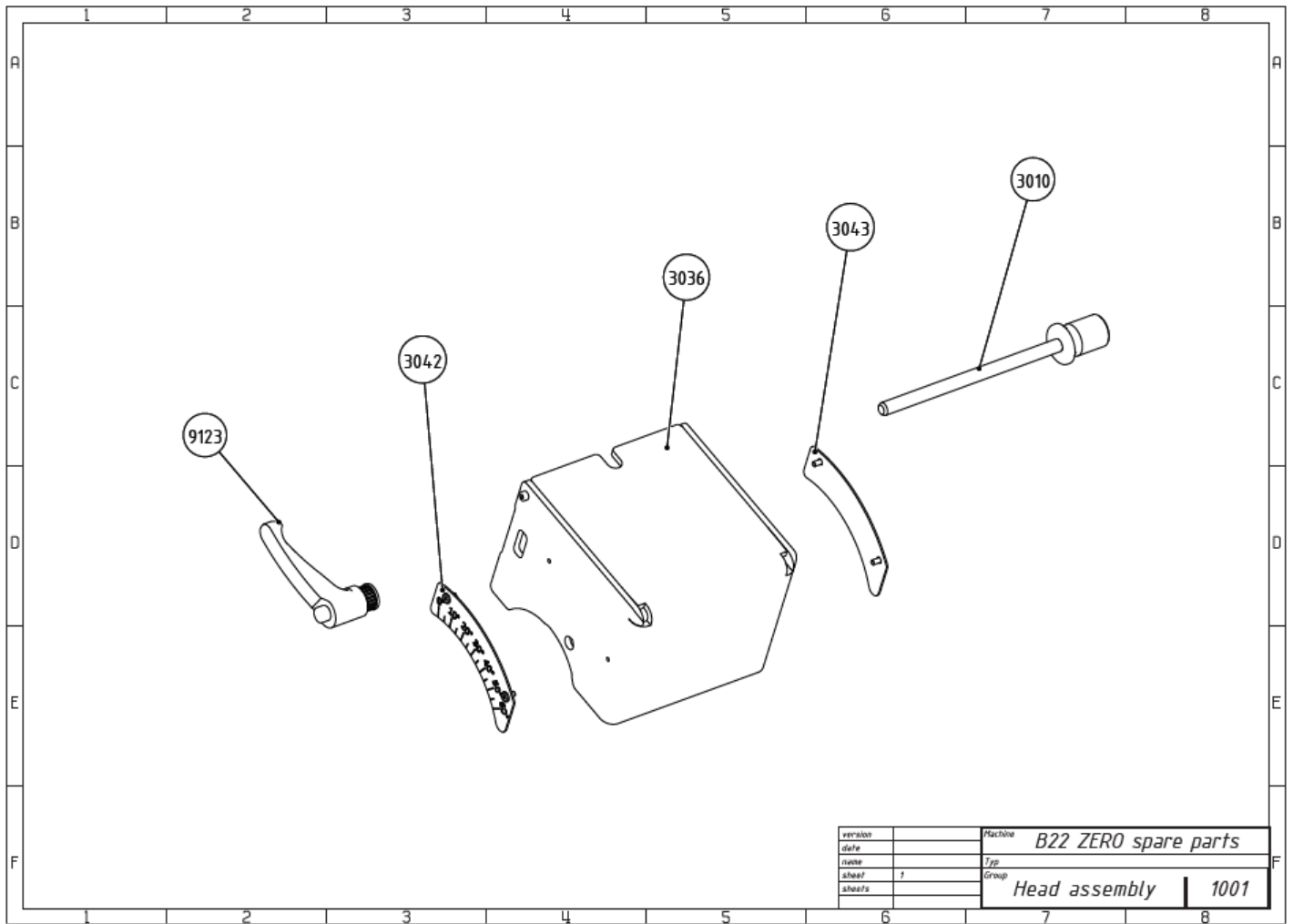

version		Machine	B22 ZERO spare parts
date		Type	
name		Group	Head assembly
sheet	1		1001
sheet's			

B22 ZERO SPARE PARTS

drawing no. 1001 Head assembly

Number	Fig	Part name	Note
29200.3010	3010	safety screw	
29200.3036	3036	head	
29200.3042	3042	right angle scale	
29200.3043	3043	left angle scale	
29200.9123	9123	chucking lever	

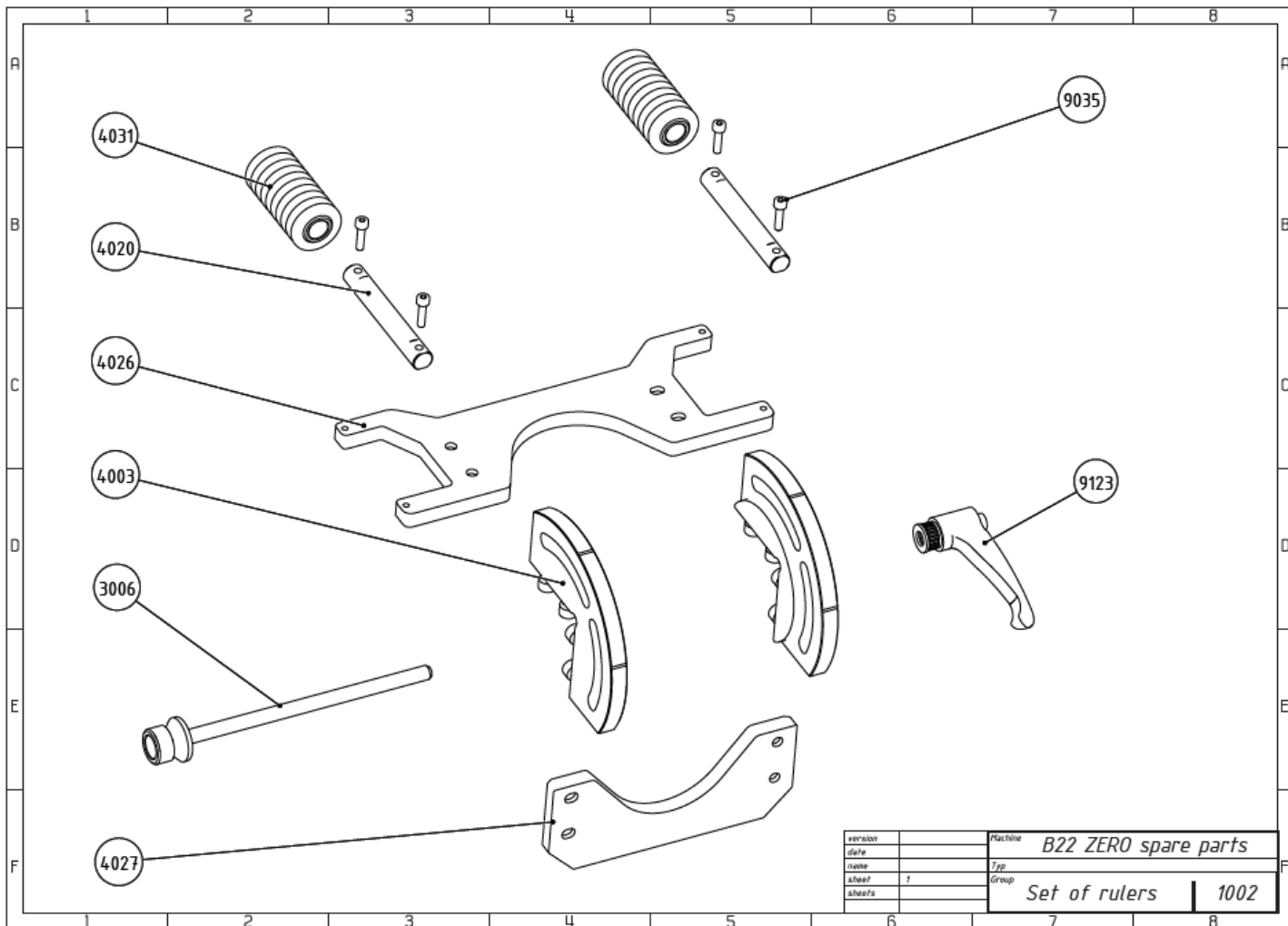

version		Machine	B22 ZERO spare parts
date		Typ	
note		Group	Set of rulers
sheet	1		1002
sheets			

B22 ZERO SPARE PARTS

drawing no. 1002 Set of rulers

Number	Fig	Part name	Note
29200.3006	3006	safety screw	
29200.4003	4003	half-moon	
29200.4020	4020	peg	
29200.4026	4026	long ruler	
29200.4027	4027	short ruler	
29200.4031	4031	roller	
29200.9035	9035	screw	
29200.9123	9123	chucking lever	

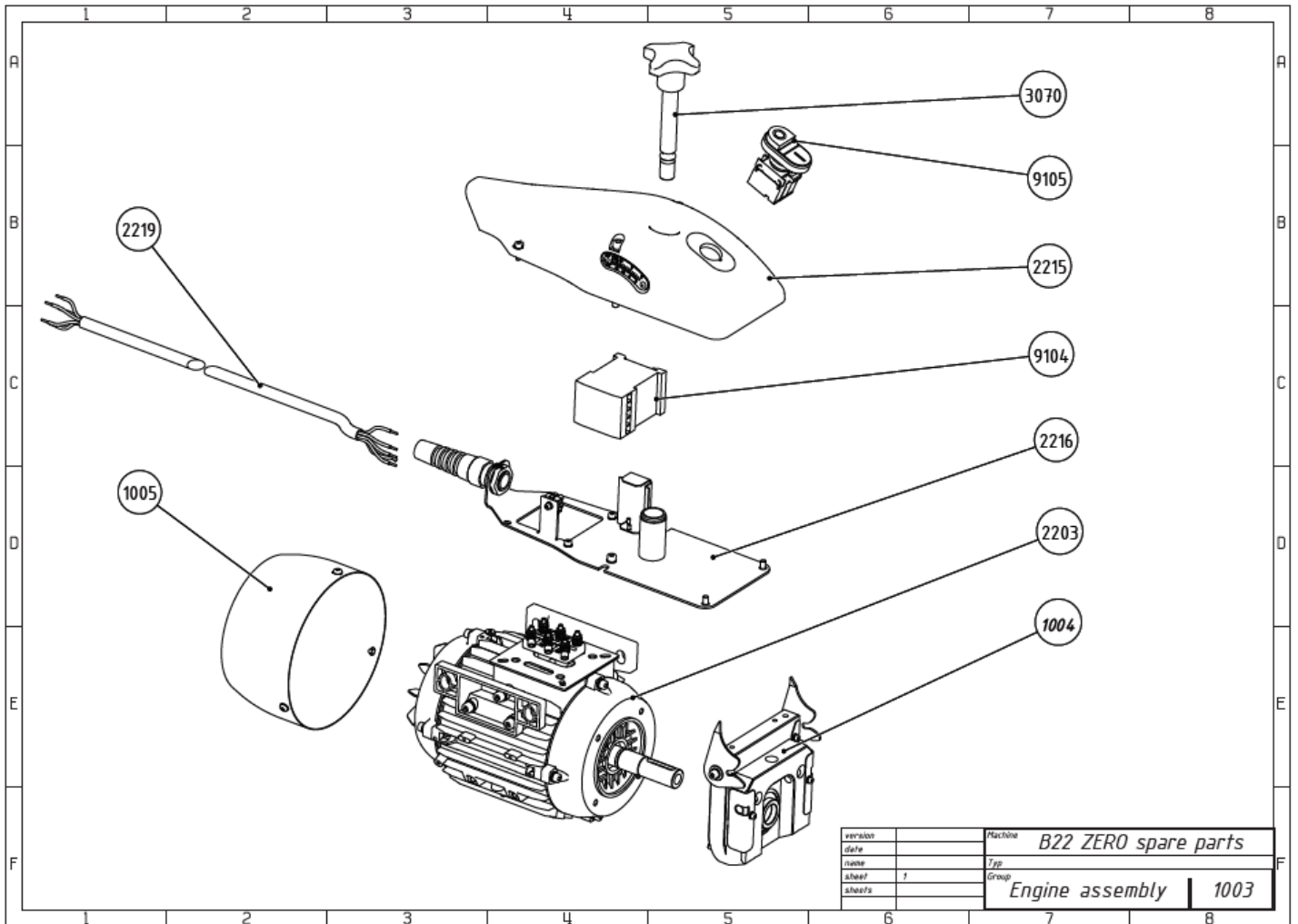

B22 ZERO SPARE PARTS

drawing no. 1003 Engine assembly

Number	Fig	Part name	Note
29200.1004	1004	adaptor	see assembly list 1004 Adaptor
29200.1005	1005	engine cover	
29200.2203	2203	asynchronous engine	
29200.2215	2215	cover	
29200.2216	2216	electroboard	
29200.2219	2219	cable	
29200.3070	3070	setting unit	
29200.9104A	9104	clamper	400V/50Hz, 3x220V/60Hz
29200.9104B	9104	clamper	480V/60Hz
29200.9105	9105	switch	

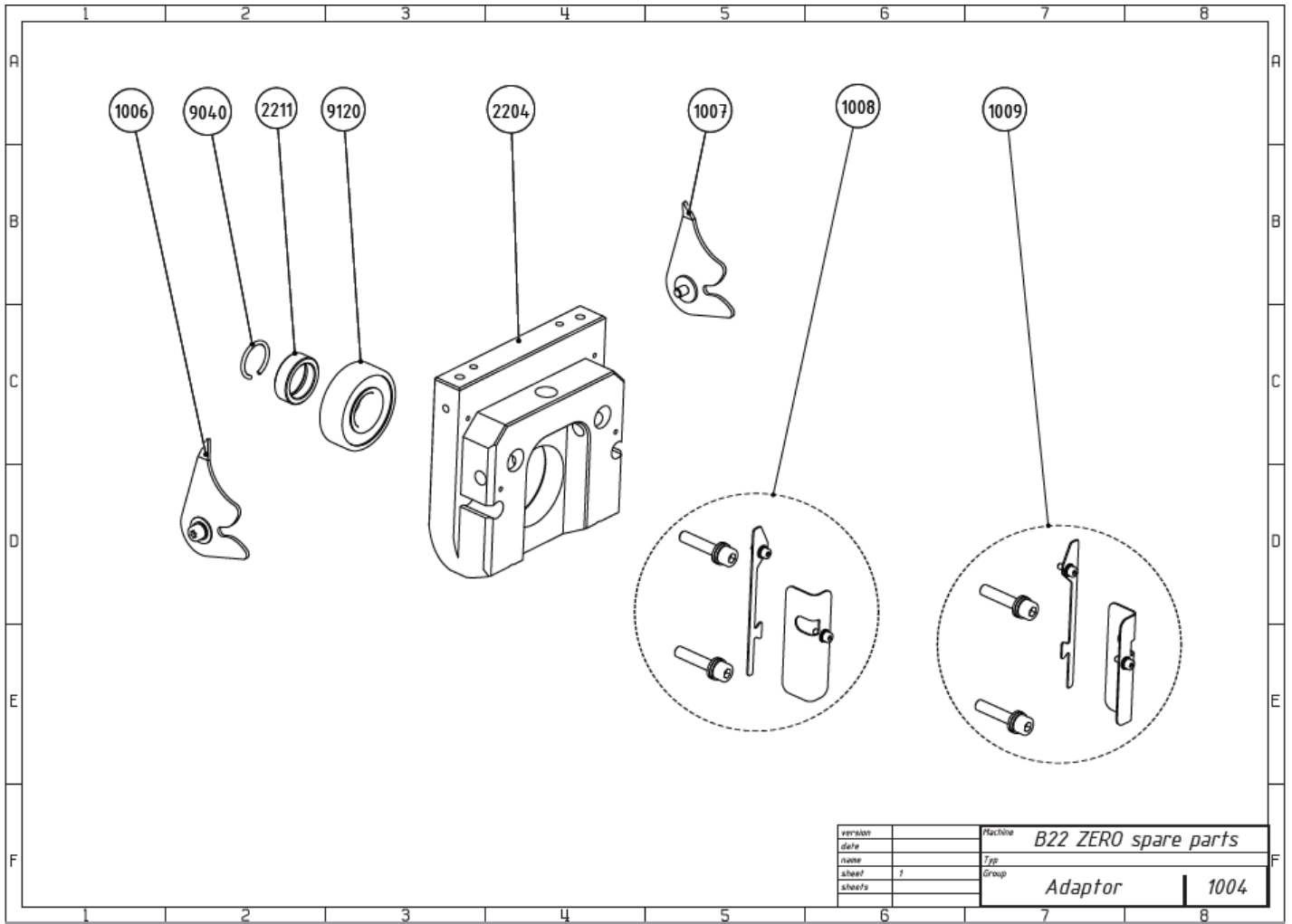

B22 ZERO SPARE PARTS

drawing no. 1004 Adaptor

Number	Fig	Part name	Note
29200.2204	2204	adaptor	
29200.2211	2211	supporting ring	
29200.9040	9040	safety ring	
29200.9120	9120	ball bearing	
29200.1006	1006	right pointer	
29200.1007	1007	left pointer	
29200.1008	1008	right set of screws and pads	
29200.1009	1009	left set of screws and pads	

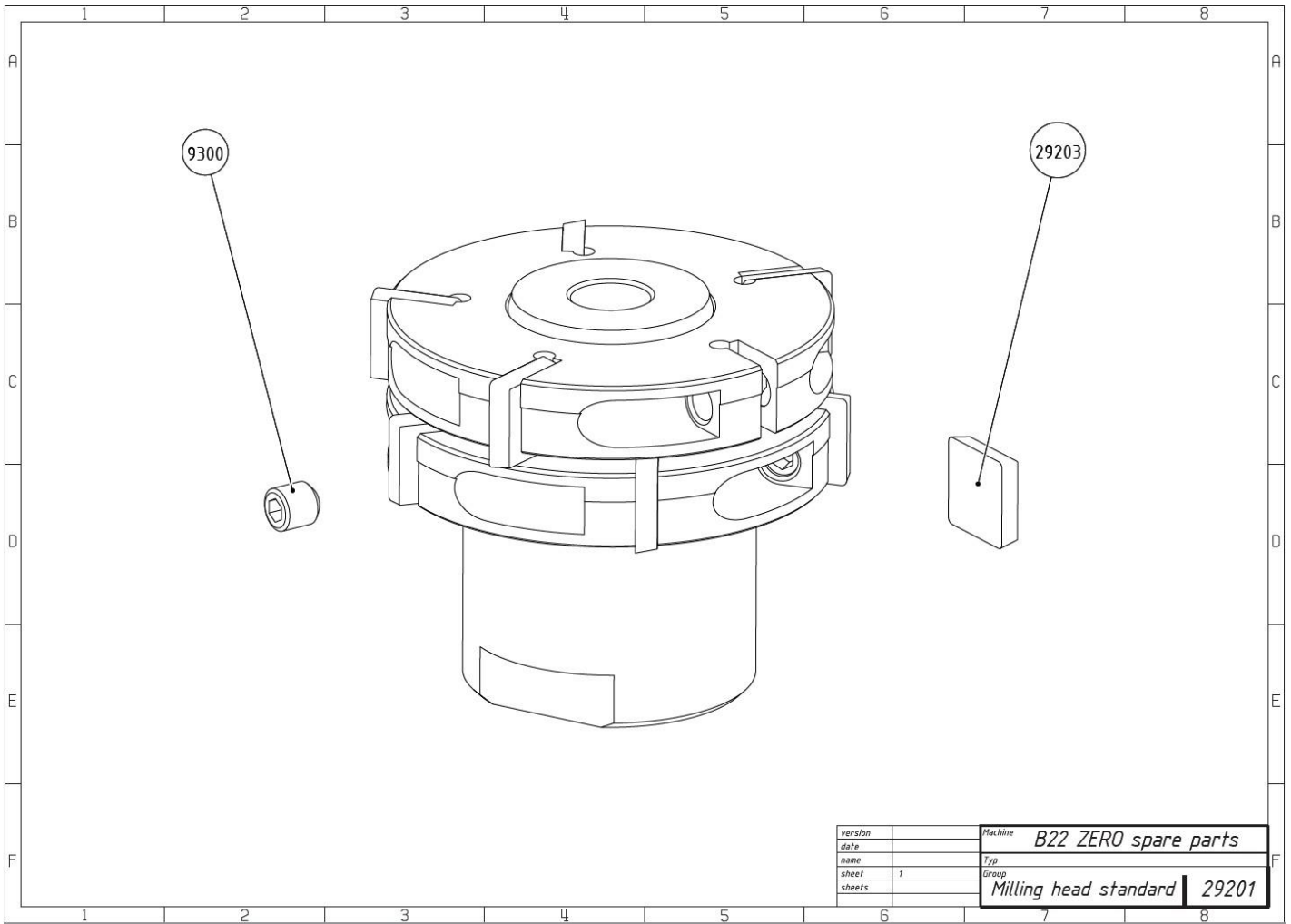

B22 ZERO SPARE PARTS

drawing no. **29201** Milling head standard

Number	Fig	Part name	Note
29203	29203	insert	
29200.9300	9300	screw	

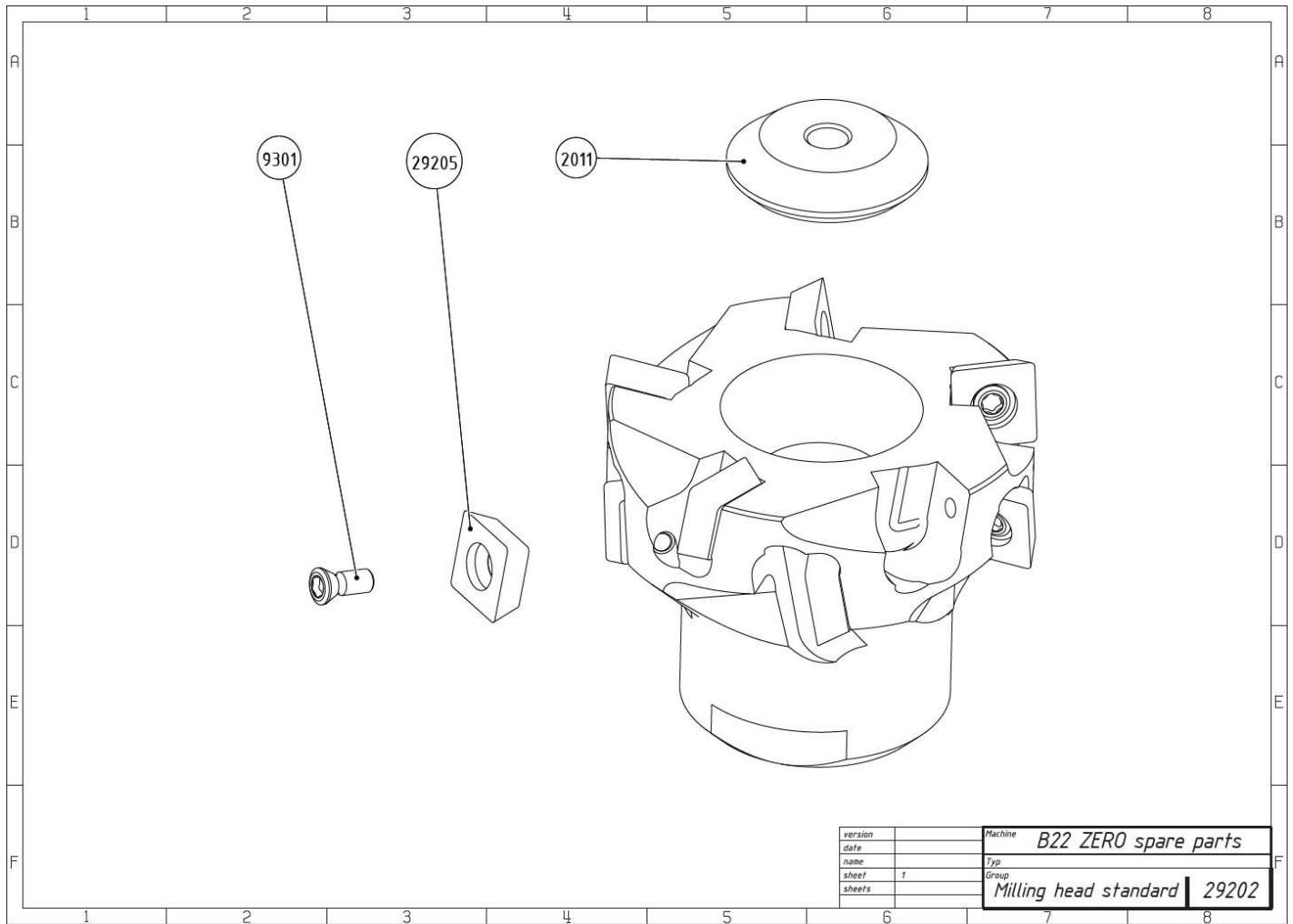

version		Machine	B22 ZERO spare parts
date		Typ	
name		Group	
sheet	1	Milling head standard 29202	
sheets			

B22 ZERO SPARE PARTS

drawing no. **29202** Milling head premium

Number	Fig	Part name	Note
29205	29205	insert	
29200.2011	2011	washer	
29200.9301	9301	screw	

A copy of this manual is supplied with every machine

B22 ZERO

All rights reserved.

No part of this publication may be reproduced without the previous consent granted by the company N.KO.

Manufacturer's and Distributor's Address:

N.KO spol. s r.o.
a Member of Richtr Group
Táborská 398/22
293 01 Mladá Boleslav
Czech Republic – Europe Union
Phone: +420 326 772 001 fax: +420 326 774 279
email:nko@nko.cz

USA Distributor's Address:

BEVELER USA INC.
a Member of Richtr Group
Business Office, Workshop, Warehouse

328 14th Street
Ambridge, PA 15003

Toll Free Number: 1-800-973-1138
Phone Ambridge (PA) office: 1-412-452-2563
email:service@bevelerusa.com