

Extra

Gravity bed coolant filter

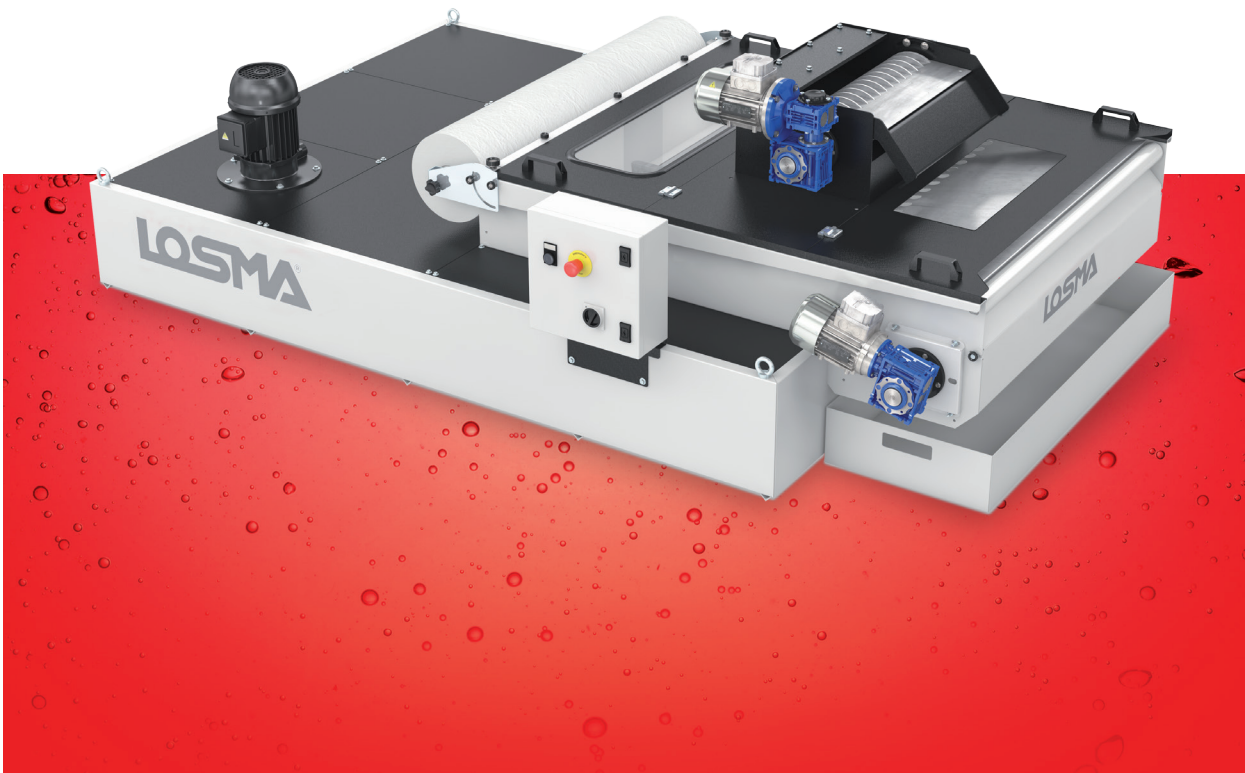

Extra

Extra and Extra High are two new gravity bed filters for coolants, which uses non-woven filtration tissue for eliminating magnetic and non-magnetic particles from neat oils and emulsions.

Filtration degree is set thanks to the tissue choice and varies from 10 to 50 microns, securing a very high depuration level.

Extra is available in two versions, normal and with augmented depth, with 11 models for throughput from 50 to 300 l/min for neat oils and from 100 to 600 l/min for emulsion.



LOSMA guarantees that every single unit is individually tested through strict control procedures. Each unit is issued a test certificate for quality and function.

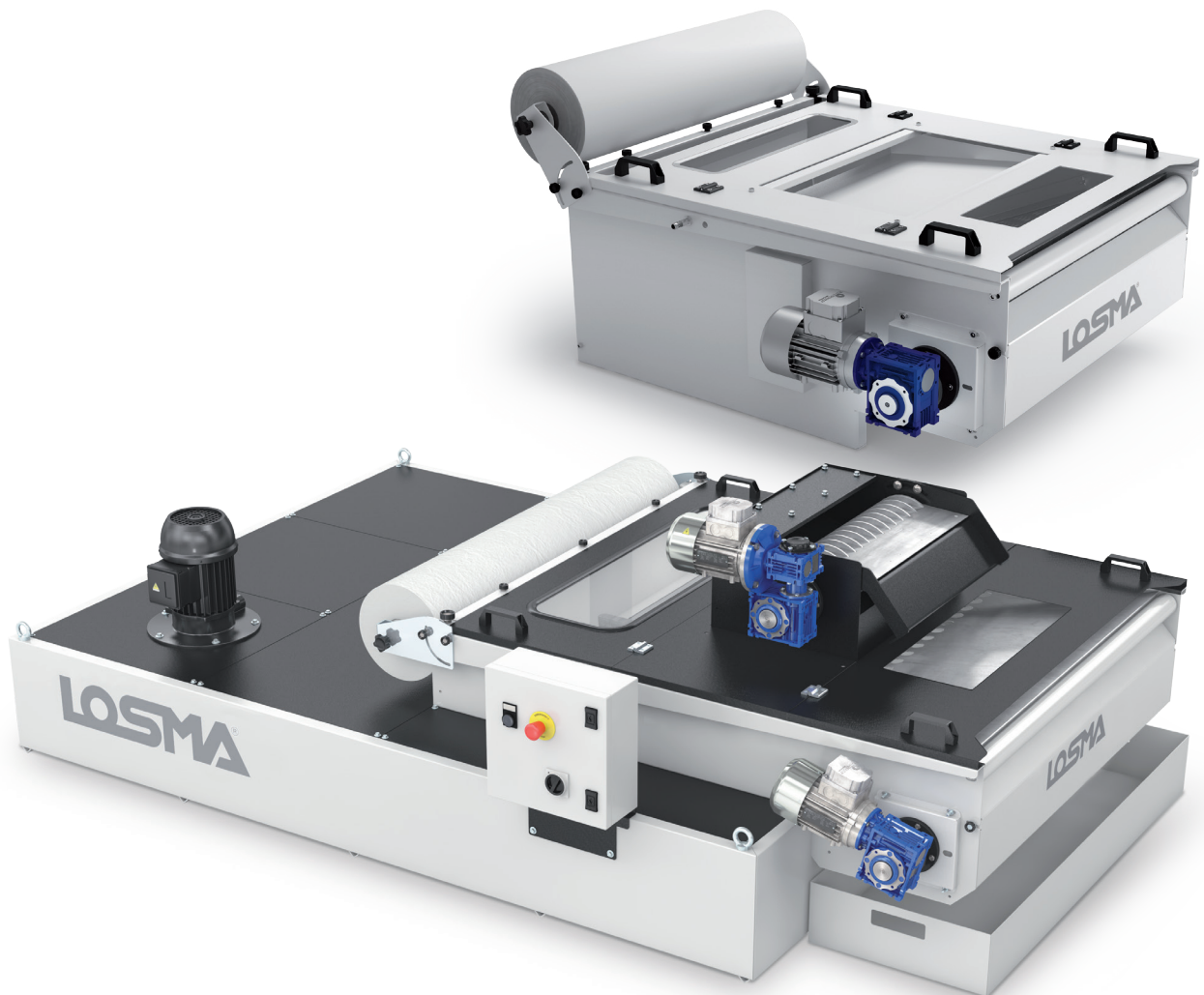

Working principles

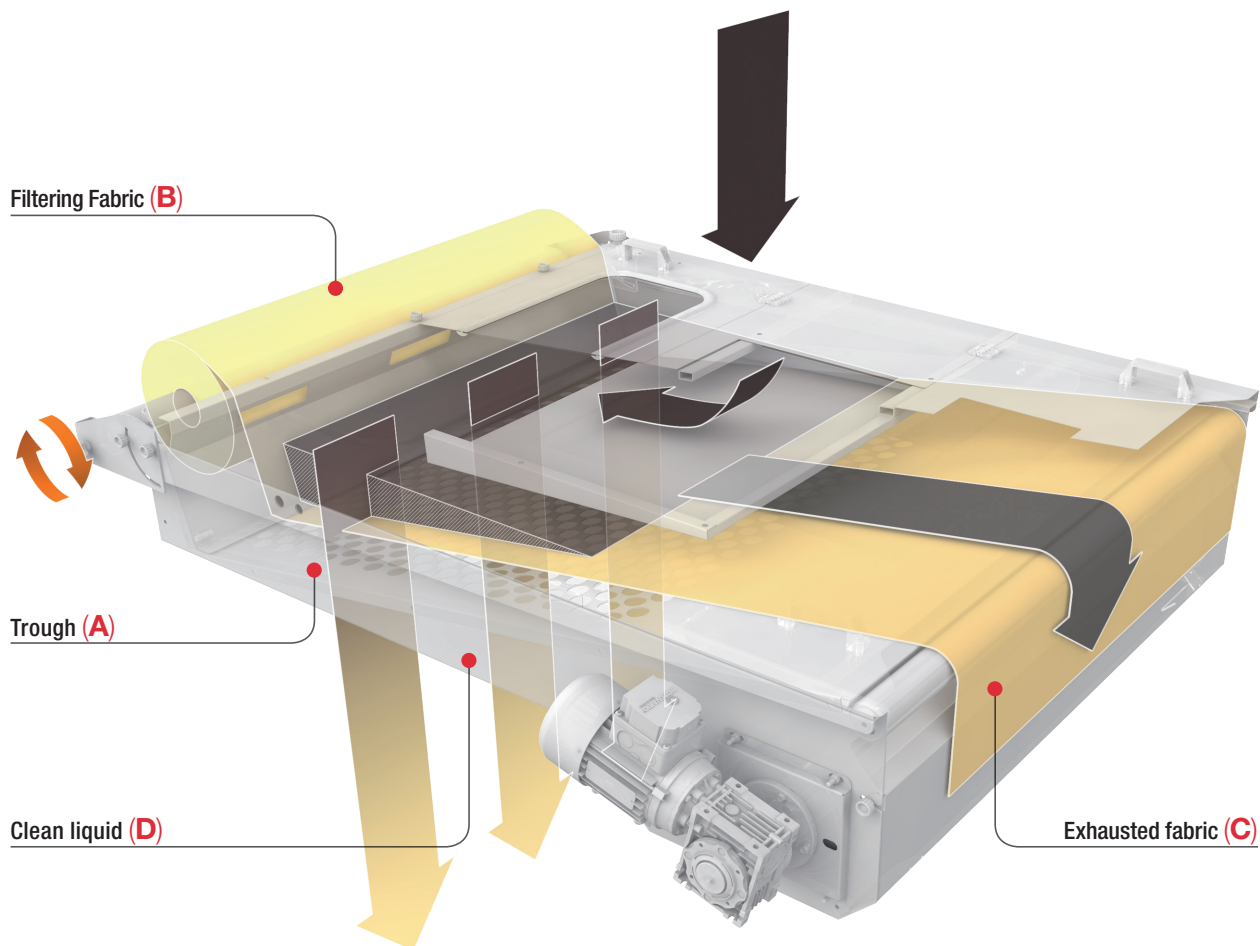

- 1** Contaminated coolant is piped into the trough (A) and distributed on the filtration fabric (B), retaining pollutant particles and allowing the cleaned coolant to pass.
- 2** The fabric collects pollutant particles until it is full and the coolant cannot cross it anymore. The coolant rises its level touching a float, which actions the proximity sensor controlling the fabric movement and the

replacing with the new one.

- 3** Dirty Fabric (C) is rewound with a dedicated system, while sludge are separated from a scraping blade.
- 4** The clean liquid pass in the tank below (D) and is sent back to the machine tools thanks to the dedicated electrical pump.

Plus

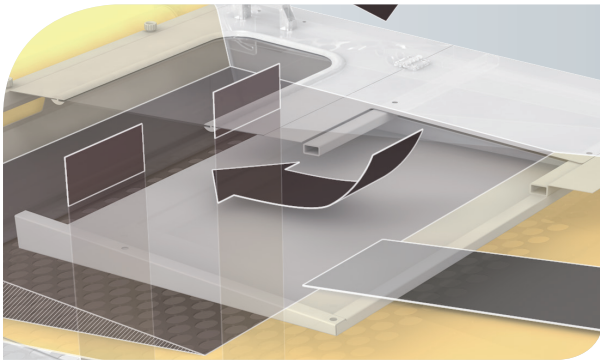

HIGH EFFICIENCY AND LOW CONSUMPTION

This system with inclined bed secures to Extra and Extra High version a maximum level of hydrostatic flow, which arises the medium filtration level and at the same time reduces the filtration tissue consumption.

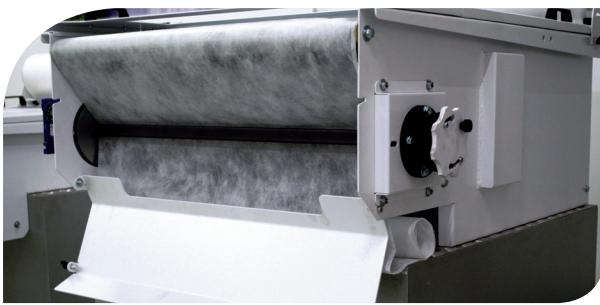

VERSATILITY

Filtration systems of Extra series are supplied with a rewinding system.

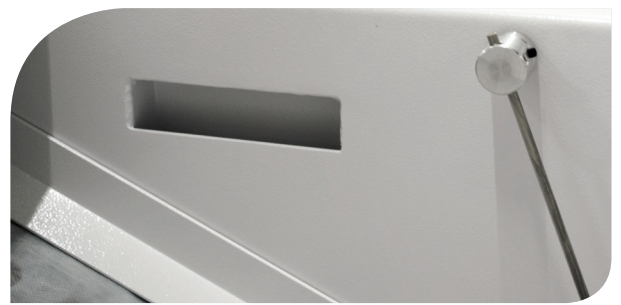

HYDRAULIC GUARD

(Only for Extra High) a double system of spill door, positioned on the two sides of the frame avoids any overflow phenomena caused by a wrong working of the dragging system.



PROXIMITY

The use of proximity sensors for the control of tissue movement, instead of the push-piece spring, allows a precise movement avoiding any tissue waste.



STAINLESS STEEL VERSION

Extra and Extra High are also available in stainless steel version, ideal to filter water, salty or corrosive liquids typical in the mechanical machining sector or in the chemical, pharmaceutical and food industry.

Optional

Skim

Superficial oil skimmer, it allows to lengthen coolant quality and eliminate odors generated by anaerobic bacteria.

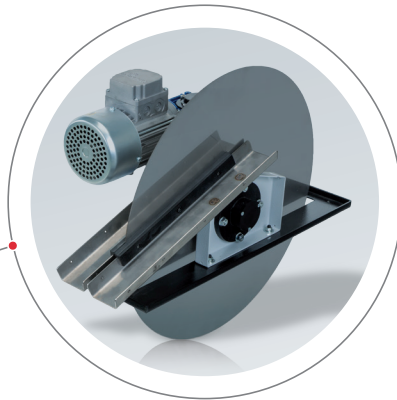

DMD

Pre-filtration system with rotating magnetic discs for the separation of magnetic polluting particles from coolant.

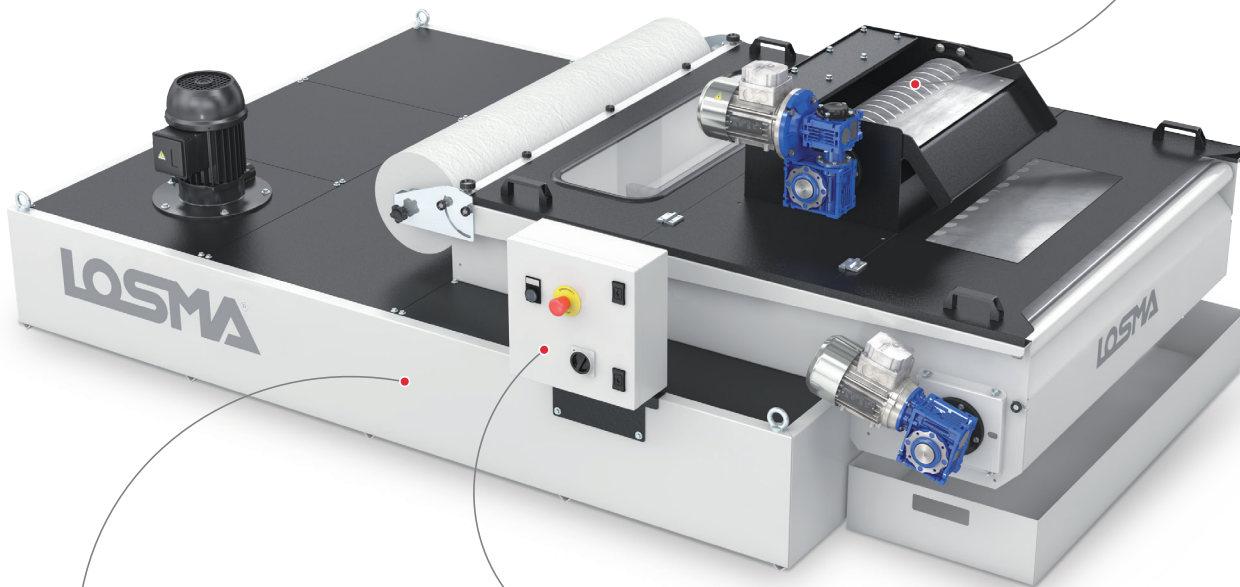

Collecting tank

For clean liquid to be sent back to machine tool.

Electrical panel

For powering the system, control and command all signals.

Transfer tank

To collect dirty liquid for feeding the filter

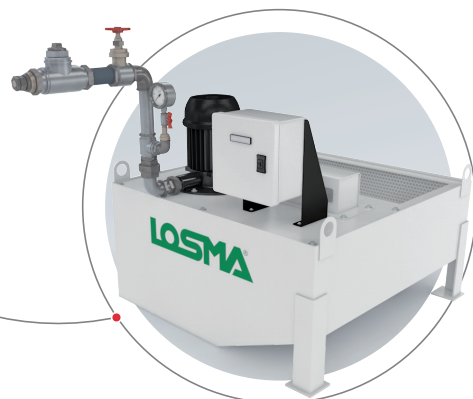

Extra Technical data

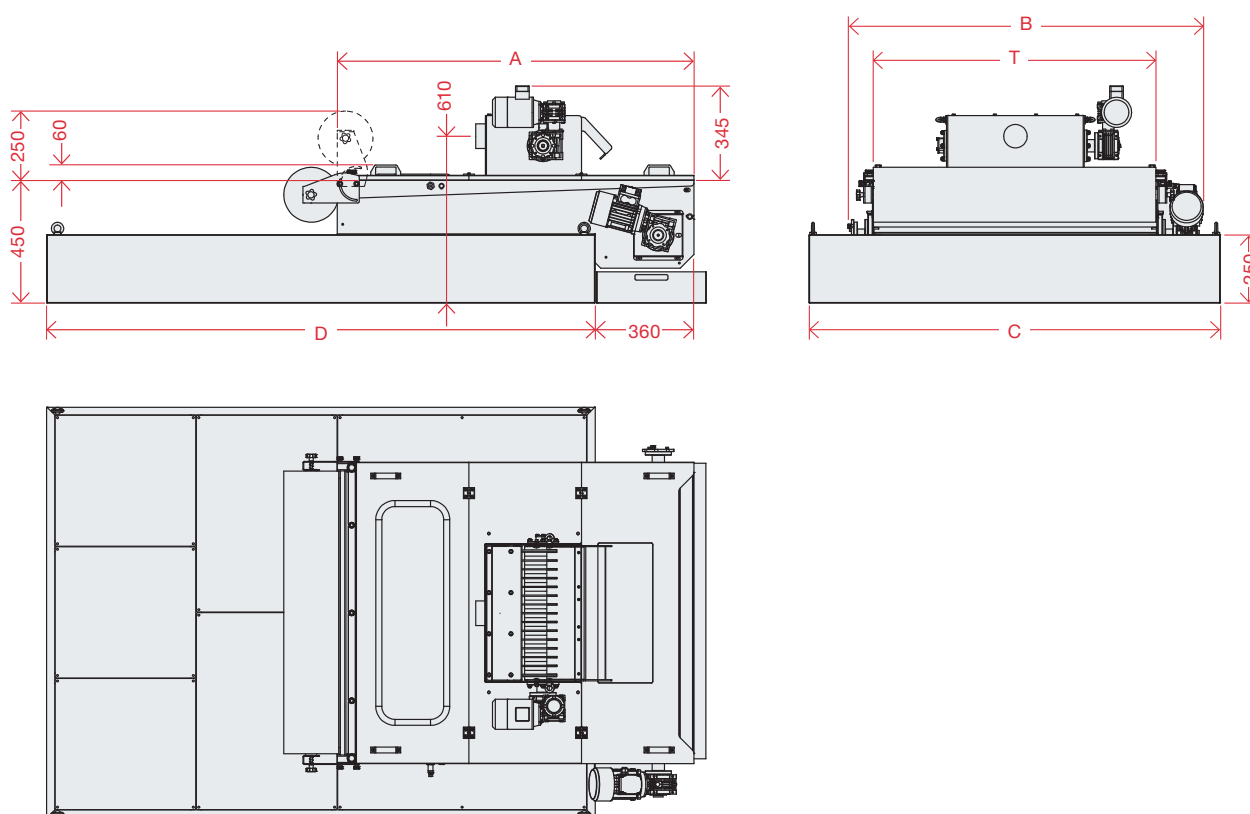

EXTRA	Dimensions (mm)					
	A	B	C	D	E	T
EXTRA R 100	1000	795	1000	1500	640	530
EXTRA R 150	1000	995	1000	1500	640	730
EXTRA R 200	1300	1195	1200	2000	940	930
EXTRA R 250	1300	1295	1200	2000	940	1030
EXTRA R 300	1500	1495	1500	2600	1140	1230
EXTRA R 350	1500	1695	1500	2600	1140	1430

EXTRA	Tank capacity	Max filtering cap. emulsion	Max filtering cap. neat oil	Pump pressure	Power	Input tension 230V / 50Hz	Input tension 260V / 60Hz	Input tension 400V / 50Hz	Input tension 460V / 60Hz	Weight
	l	l/min	l/min	bar	kW	A	A	A	A	Kg
EXTRA R 100	365	100	50	0,2	0,12+0,25	0,83+1,3	0,85+1,18	0,48+0,75	0,49+0,68	63
EXTRA R 150	365	150	75	0,2	0,12+0,37	0,83+1,65	0,85+1,45	0,48+0,95	0,49+0,84	69
EXTRA R 200	490	200	100	0,2	0,12+0,53	0,83+2,7	0,85+2,7	0,48+1,6	0,49+1,6	82
EXTRA R 250	490	250	125	0,2	0,12+0,78	0,83+3,3	0,85+3,3	0,48+1,9	0,49+1,9	87
EXTRA R 300	955	300	150	0,2	0,12+1,15	0,83+3,3	0,85+3,3	0,48+1,9	0,49+1,9	99
EXTRA R 350	955	350	175	0,4	0,12+1,47	0,83+4,8	0,85+4,8	0,48+2,8	0,49+2,8	107

* Flow rates data refers to emulsion with a max. oil concentration of 5% or neat oil with a max. viscosity of 20cst at 40°C, and with a filtering media having a weight not over 35g/m². Different characteristics of the coolant to be treated, pollutant typology and its concentration could considerably influence the filtration system's performances. Our Technical Dept. is available for studying the best solution for your requirements.

Extra High Technical data

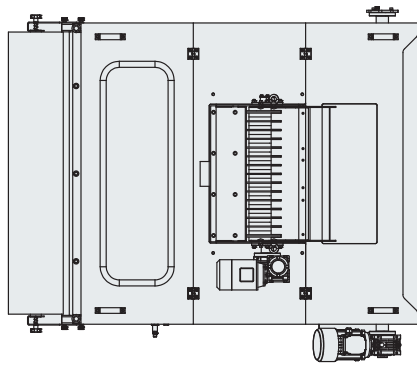
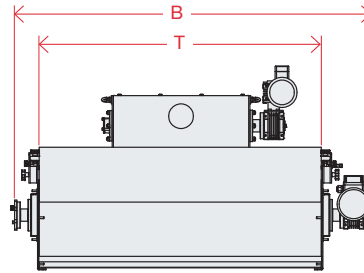
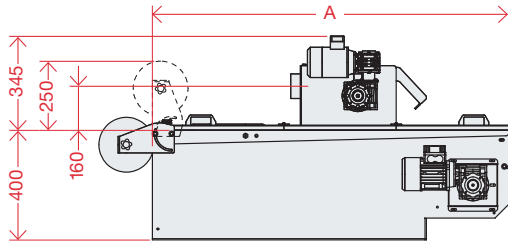

EXTRA HIGH	Dimensions (mm)			
	A	B	C	T
EXTRA HIGH 150	1000	795	700	530
EXTRA HIGH 250	1000	995	700	730
EXTRA HIGH 350	1300	1295	1000	1030
EXTRA HIGH 450	1300	1495	1000	1230
EXTRA HIGH 600	1500	1695	1200	1430

EXTRA HIGH	Tank capacity	Max filtering cap. emulsion	Max filtering cap. neat oil	Power	Input tension 230V / 50Hz	Input tension 260V / 60Hz	Input tension 400V / 50Hz	Input tension 460V / 60Hz	Weight
	l	l/min	l/min	kW	A	A	A	A	Kg
EXTRA HIGH 150	On request	150	100	0,12	0,83	0,85	0,48	0,49	75
EXTRA HIGH 250	On request	250	125	0,12	0,83	0,85	0,48	0,49	83
EXTRA HIGH 350	On request	350	175	0,12	0,83	0,85	0,48	0,49	106
EXTRA HIGH 450	On request	450	225	0,12	0,83	0,85	0,48	0,49	115
EXTRA HIGH 600	On request	600	300	0,12	0,83	0,85	0,48	0,49	131

* Flow rates data refers to emulsion with a max. oil concentration of 5% or neat oil with a max. viscosity of 20cst at 40°C, and with a filtering media having a weight not over 35g/m². Different characteristics of the coolant to be treated, pollutant typology and its concentration could considerably influence the filtration system's performances. Our Technical Dept. is available for studying the best solution for your requirements.



Health



Savings



Efficiency



Environment



Safety



Losma SpA

HQ:

Via E. Fermi, 16 - 24035 Curno - Bergamo
Tel. +39 035 461444 - Fax +39 035 461671
info@losma.it - www.losma.it

Turin office:

Via G. Brunero, 2 - 10077 San Maurizio Canavese - Torino
Tel. +39 011 9275631
info@losma.it - www.losma.it



ISO 9001
TUV SUD
Certified
Company



ISO 14001
TUV SUD
Certified
Company



Autorizzato
all'utilizzo

Losma GmbH

Albert-Einstein-Str. 2 - 70806 Kornwestheim
Tel. +49 7154 8160480 - Fax +49 7154 8160485
info@losma.de - www.losma.de

Losma Inc.

30A Wilson Drive - Sparta - NJ 07871
Tel. +973 248 0070 - Fax +973 940 0950
info@losmausa.com - www.losma.com

Losma UK Ltd.

6 Strensham Business Park
WR8 9JZ Strensham Worcestershire
Tel. +44 (0)1684 276527 - Fax +44 (0)1684 276470
info@losma.co.uk - www.losma.co.uk

Losma Pvt Ltd.

Plot No 7A, Gat. No. 63, Shindewadi
Tal: Bhor, District: Pune - 412205 - Maharashtra
Tel. +91 9226107775
info@losma.in - www.losma.com