

HUAHENG

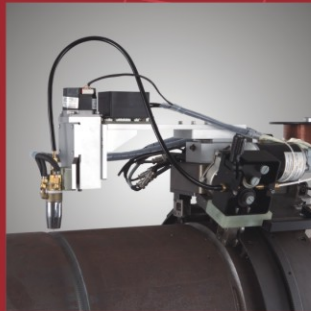

ORBITAL Welding System

HUAHENG WELDING CO., LTD.

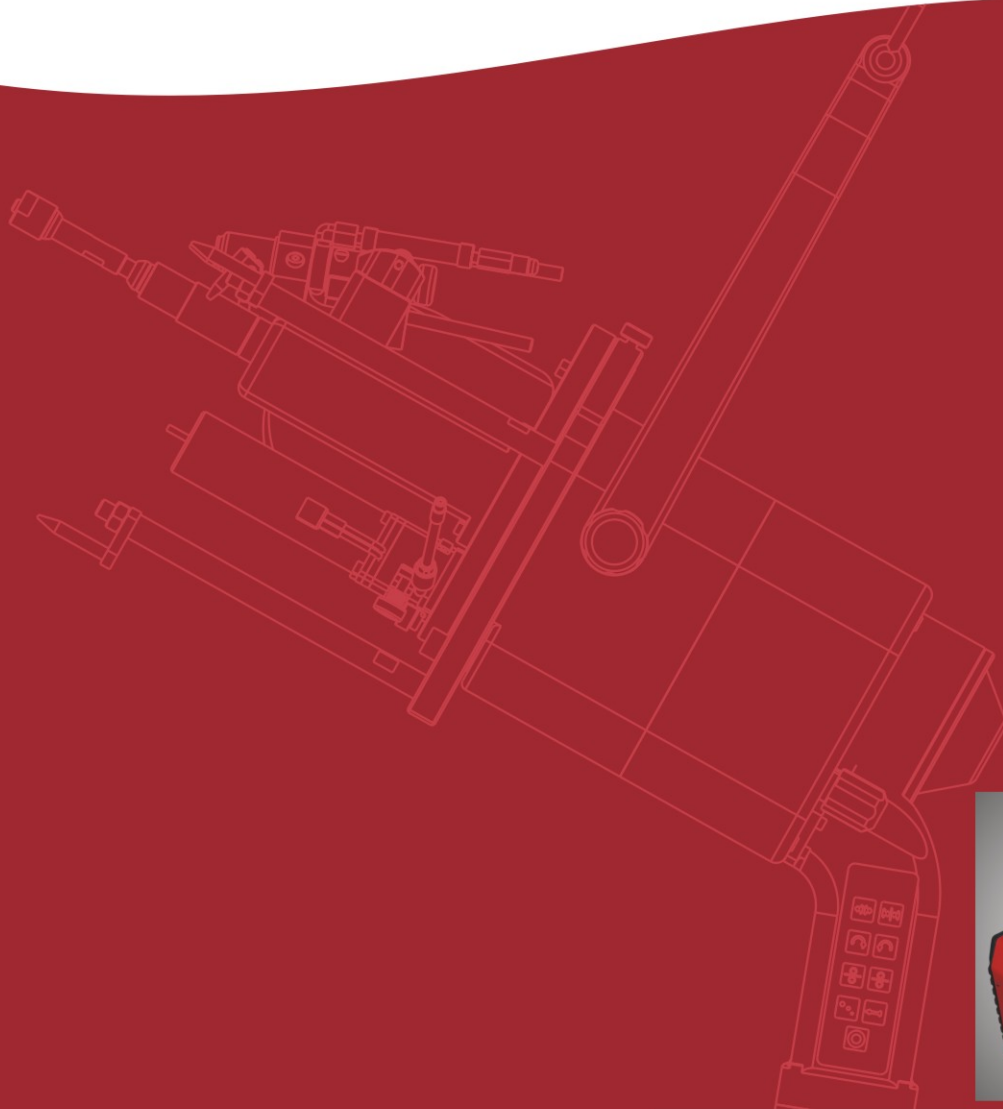
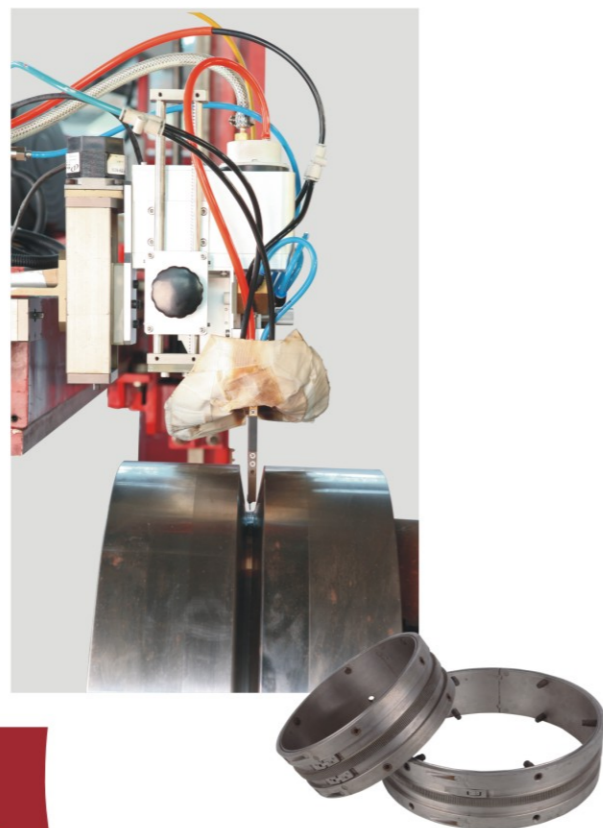

TIG 1G/5G Narrow Groove Welding System

Hot wire Cold wire



Brief Introduction

This system is made up of torch angle swinging part, torch fixing part, back protective gas hood, gas hood lifting part, wire feeding frame, camera monitoring system and electric sliding part. The torch fixing part is made by high temperature resistant insulation material, insure long time working and integrated circuit water and protective gas channels. Inner protective gas hood is made up of stainless steel, water cooling. The connection part with torch is isolated by insulation material, which could effectively protect the root of pass and external surface while doing groove welding.

Application: Thick work-piece in nuclear, chemical, boiler, valve, shipbuilding, power plant and so on.

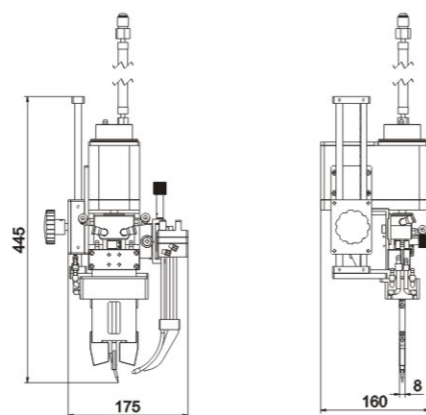

Features

- Suitable for bevel width more than 9mm narrow bevel welding;
- Make both sides completely welding by moving of tungsten;
- High deposition efficiency, low heat input;
- Welding method: Horizontal, vertical and orbital welding;
- Special 5 channels water cooling, high duty cycle;
- Double gas protection, ensure welds quality;
- Convenient to change and maintain consumable parts, less consumable and low cost;
- Suitable for carbon steel, stainless steel, nickel base alloy and Titanium alloy.

Technical Specification

Bevel type	U, J type
Tube thickness (mm)	30-200
Bevel width (mm)	9-20
Max current (A)	350
Max wire feeding speed (mm/min)	5500
Wire diameter (mm)	1.0-1.2
Protective gas	Ar 99.99%
Cooling	Water
Weight (kg)	7
Dimension (mm)	175 x 160 x 445



HUAHENG

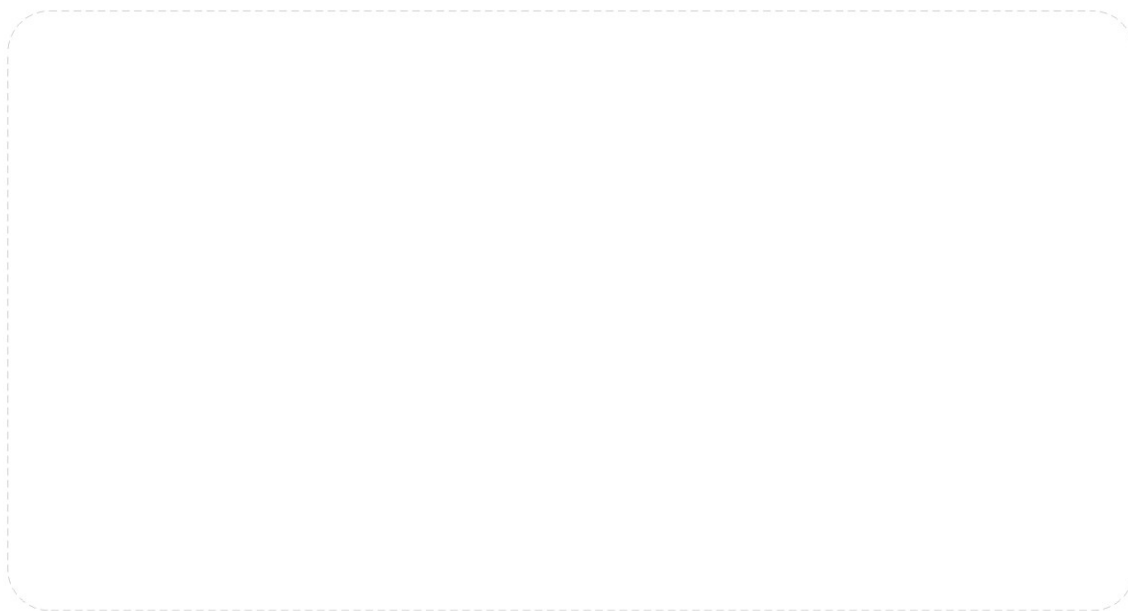

HUAHENG
HUAHENG WELDING CO., LTD.

Add : No.1588 Boshi Road,Kunshan,Jiangsu,P.R.China. PC: 215347
Tel : +86(0)512-81866666 Fax : +86(0)512-57328188
www.huahengweld.com E-mail : info@huahengweld.com